

MATERIALS & RESEARCH

Reviewed by:
Donald H. Lathrop
Donald H. Lathrop, P.E.
Materials and Research Engineer



Prepared by:
Lindsay Ashworth
Lindsay Ashworth
Research Engineer
June 6, 2003

INSTALLATION REPORT

U 2003-4

GALVASHIELD XP SACRIFICIAL ANODES

REFERENCES:

WP 2001-R-4

INTRODUCTION:

Sacrificial Anodes provide protection against corrosion by corroding themselves preferentially to the surrounding steel. In rehabilitation projects an increased rate of corrosion is caused by the differential in chloride concentrations between the new patching concrete and the existing concrete. Installing sacrificial anodes at the edge of the patched areas can alleviate some of the corrosion potential in the surrounding steel due to the chlorides in the concrete. The manufacturers have estimated the life of the Galvashield XP Sacrificial Anodes to be within the range of 10-20 years.

MATERIALS:

Galvashield XP Embedded Galvanic Anodes and Test Kits supplied by Vector Corrosion Technologies of Manitoba, Canada (1) See Appendix A for Product Literature.

The Galvashield XP Anode consists of a zinc core surrounded by an active cementitious matrix protected by lithium. The anodes are approximately 2 1/2" in diameter and 1 1/8" thick. With 2 metal ties attached to either side of the anode.

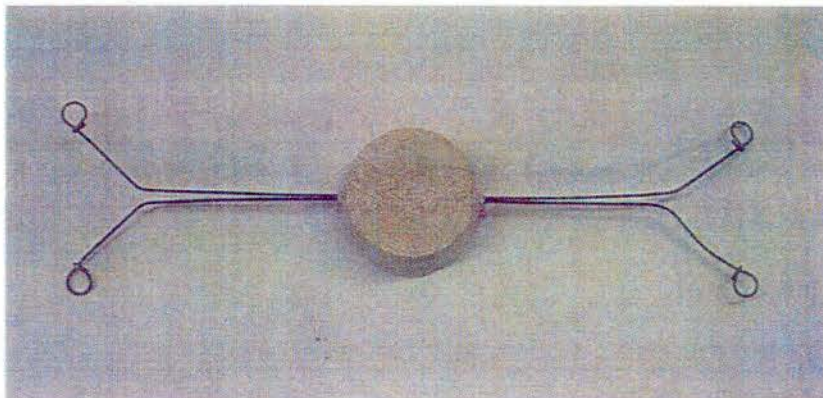

Galvashield XP Sacrificial Anode

The Galvashield XP Anode Test Kit includes an anode with one anode lead wire attached (the red wire), one cathode lead wire (the black wire), a hose clamp, and a switch.

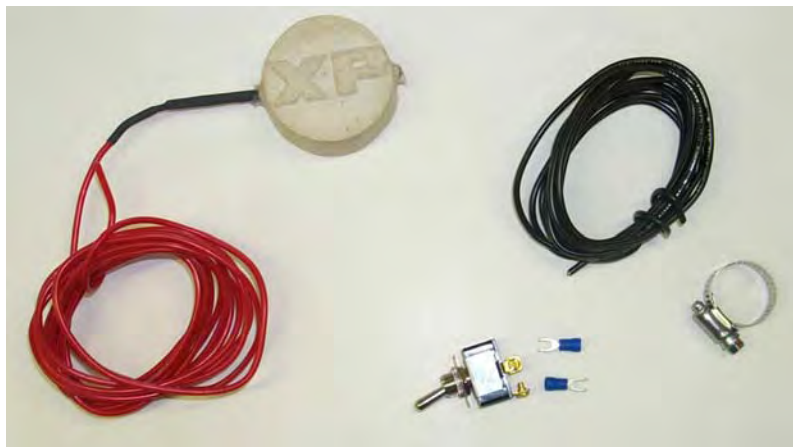

Galvashield XP Anode Test Kit

LOCATION:

I-89 Bridges 43N, 43S, 48N, 48S, 50N, including pier caps and abutment repairs. Monitoring test kits were installed on both piers of 48N and 48S (See Appendix E for photos). The following table summarizes the number of anodes in each portion of the bridges. Also see Appendix B for a more detailed description of the locations of the anodes and test kits.

Galvashield Anode Locations						
	43N	43S	48N	48S	50N	Totals
Pier Cap	30	0	99	167	30	326
<i>Test Kits</i>			6	3		9
Stem Repair	8	24	176	232	0	440
<i>Test Kits</i>			6	5		11
Footing Repair	0	0	28	23	0	51
<i>Test Kits</i>			0	0		0
Total Anodes	38	24	303	422	30	817
<i>Total Test Kits</i>	0	0	12	8	0	20

INSTALLATION PROCEDURES:

1. The deteriorated concrete was removed by chipping, exposing the reinforcing steel.
2. The steel was then cleaned by mechanical means, sandblasting or brushing.
3. Anodes were placed just above the old concrete at two foot intervals and tied into place using a rebar tying tool.
4. Test kit anodes were placed in the stem and pier cap of bridges 48N & S. These were secured to the rebar using epoxy coated rebar ties and silicone. The ground wire was attached to the rebar using a hose clamp and silicone.
5. The area was formed and poured according to specifications.
6. The leads coming from the test kits were left hanging out of the finished concrete. Later they were enclosed in a conduit and ran to a central box at each pier.
7. Inside the central box, the leads were attached to a switch for each anode. The switches are numbered and indexed to a location diagram inside the cover to the box.
8. Measurements of current and voltage can be taken by attaching a multimeter to the leads going into the switch.



Galvashield XP Anode and Test Kit installed in the Cap of Pier 2 on Br. 48N

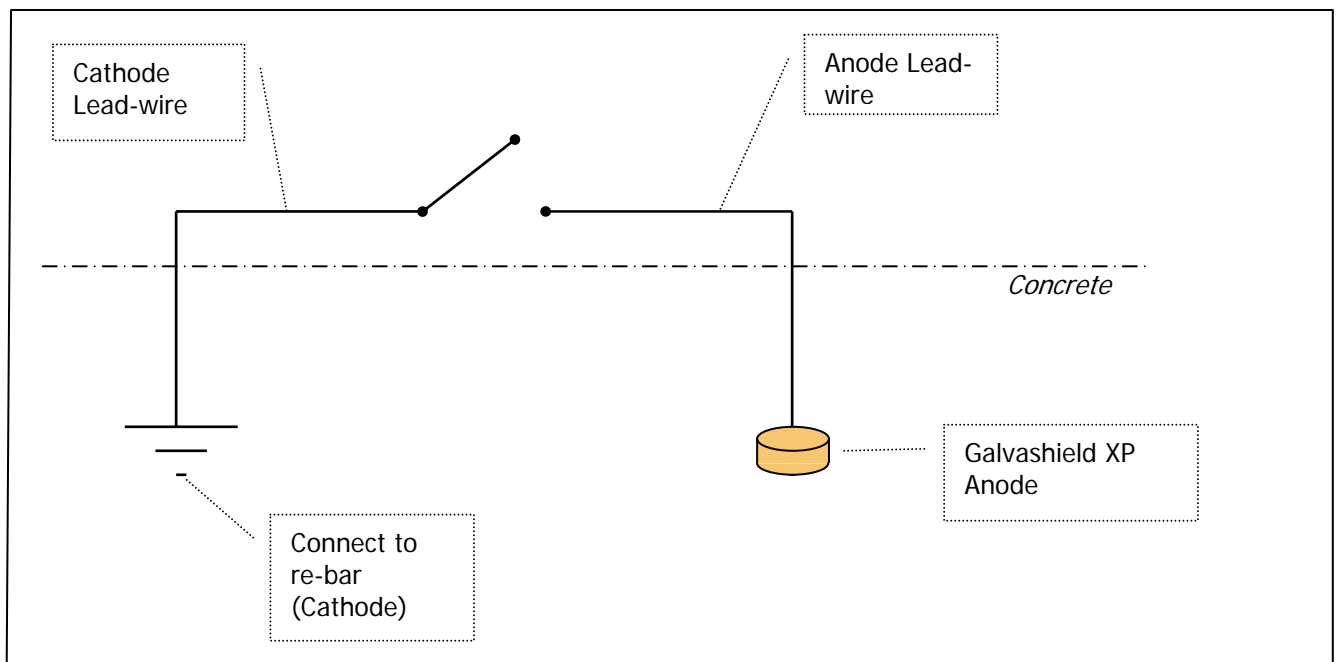

Schematic of Galvashield XP Test Kit

Also see Appendix C for the manufacturer's installation and monitoring instructions.

INITIAL READINGS:

Initial readings were taken on all anodes on November 26, 2002 by VTrans Research and Testing staff. In order to collect readings from the test kits, a multimeter was attached to the leads going into the switch, and the switch opened. Current was found to initially surge and then drop steadily to zero. The reading was taken at the point just before decline, approximately 2 seconds after attaching the multimeter. The voltage did not change and was recorded as read.

Bridge	Pier	Circuit	Current, uA	Volts	Location	Date Installed
48S	1	1	14	0.47	Upper Stem	10/15/2001
	1	2	120	0.3	Lower Cap	10/15/2001
	1	3	109	0.27	Lower Cap	10/15/2001
	1	4	51	0.2	Lower Stem	9/28/2001
	2	1	2	0.01	Lower Stem	9/27/2001
	2	2	1	0.04	Lower Stem	9/27/2001
	2	3	79	0.21	Upper Stem	10/11/2001
	2	4	405	0.35	Lower Cap	10/11/2001
48N	1	1	630	0.43	*	*
	1	2	50	0.11	*	*
	1	3	0	0	*	*
	1	4	128	0.26	*	*
	1	5	105	0.18	*	*
	2	1	95	0.25	Top Cap	7/16/2002
	2	2	165	0.38	Top Cap	7/16/2002
	2	3	133	0.18	Lower Cap	5/2/2002
	2	4	90	0.08	Lower Cap	5/2/2002
	2	5	146	0.19	Upper Stem	4/24/2002
	2	6	201	0.21	Upper Stem	4/24/2002
	2	7	92	0.15	Lower Stem	4/16/2002

* This information will be determined on the next field visit.

These readings have little meaning alone. Once they are coupled with a year’s worth of monthly readings we will be able to see seasonal trends and obtain an average current output for the year. This average current output can help us determine how fast the anodes are being consumed and interpret a life expectancy.

COSTS:

The materials and labor for the anode portion of this project was paid for under an extra work order. The total cost was \$35,987.83. (see Appendix D) This includes the materials and installation of 817 Anodes, 20 Test Kits, and 8 Test Kit monitoring boxes.

If the anodes were to be installed without monitoring equipment, a cost of approximately \$22.50 per anode could be expected. This price includes the material cost and the \$1.25 per anode for complete installation.

CONCLUSIONS:

Installation of the Galvashield XP Anodes and Test Kits commenced on July 02, 2001 and was completed on November 15, 2002. Anodes were installed in all bridges of the Middlesex-Bolton AC IM 089-2(26) project where new concrete was placed next to existing concrete in order to provide protection against corrosion to the reinforcing steel. No significant difficulties were encountered with the installation of the anodes.

Two circuits on Bridge 48S (Pier 2; Circuits 1 & 2) and one circuit on Bridge 48N (Pier 1, Circuit 3) are giving readings of zero or very close to zero. Since there is no voltage differential between the two leads we can conclude that a complete circuit has not been made. We assume that during construction a lead or a connection was broken therefore

disconnecting the circuit. We will continue to monitor the current output in these circuits to confirm this conclusion, with an effort to verify that external wiring connections are not at fault. This effort will be performed in conjunction with biennial bridge inspection efforts.

RECOMMENDATIONS:

Continue monitoring the current output of all the test kits for at least a full year on a monthly basis. Frequent monitoring should occur in the spring when the temperatures are just beginning to rise. Reading need not be taken when the temperatures remain below freezing, because the corrosive activity will be significantly reduced.

It is recommended that an induced current test be performed to determine the area of influence of an anode. By introducing a current into a test kit and measuring the voltage drop along the surface of the concrete it is believed that the area influenced by the anode can be determined through graphical interpolation. Three current sources of varying magnitude shall be connected to the test kit most easily accessible on each pier and a voltmeter used on the surface of the concrete to measure the voltage drop. By graphing these three currents versus the radial distance to a negligible voltage, a trend can be shown and an area determined for a current equal to that provided by the zinc in the anode. The purpose of determining this area of influence is to minimize the number of anodes needed by maximizing the spacing between anodes in future applications. This test must be performed when the concrete has thawed to give accurate results.

Appendix A

Product Literature

GALVASHIELD XP

Embedded Galvanic Anodes

Corrosion Protection for

Reinforcing Steel in Concrete Structures

Description

The Galvashield XP embedded galvanic anode consists of a zinc core surrounded by an active cementitious matrix. The palm-sized embedded anode is quickly and easily fastened to reinforcing steel. Once installed, the zinc core corrodes preferentially to the surrounding rebar, thereby providing galvanic corrosion protection to the reinforcing steel.

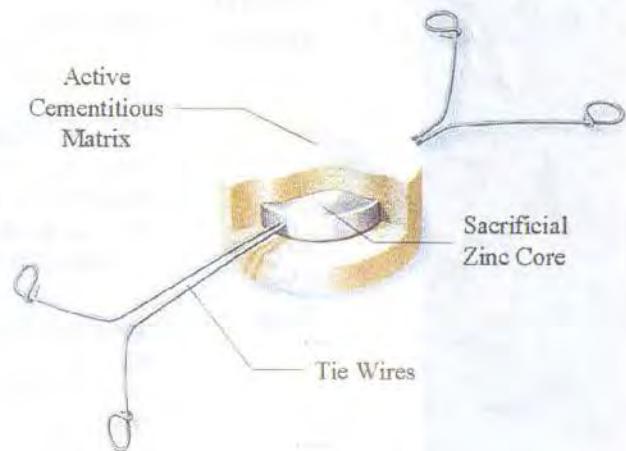

Advantages & Benefits

- Provides localized corrosion protection in reinforced concrete structures.
- Effective in chloride-contaminated and carbonated concrete.
- Economically extends the service life of concrete patch repairs.
- Low cost method of providing galvanic corrosion protection.
- Installation is quick and easy.
- Reduces need for continual re-patching and secondary repairs.
- Anode installation can be performed by locally approved applicators.
- Proven technology supported by university test program.
- Anode performance is easily monitored.

Applications

Galvashield XP anodes are suitable for deck repairs, joint replacements, pre-stressed & post-tensioned repairs and interface applications between new concrete and existing chloride-contaminated concrete where accelerated corrosion can occur. The anodes reduce on going corrosion activity and reduce the effect of "ring anode" corrosion or the "halo effect" commonly associated with concrete patch repairs in reinforced concrete (see below).

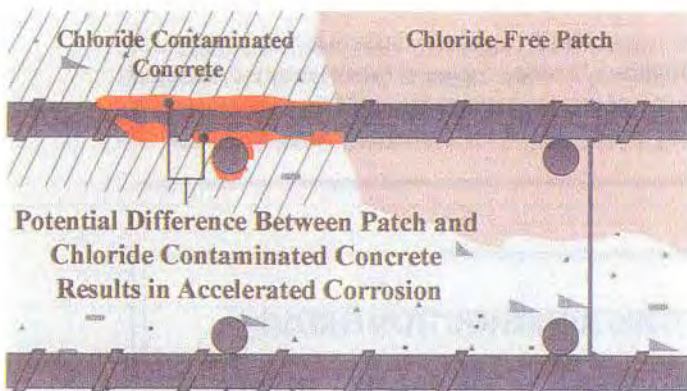

"Ring Anode" Corrosion (without Galvashield XP)



Galvashield XP Reduces "Ring Anode" Corrosion

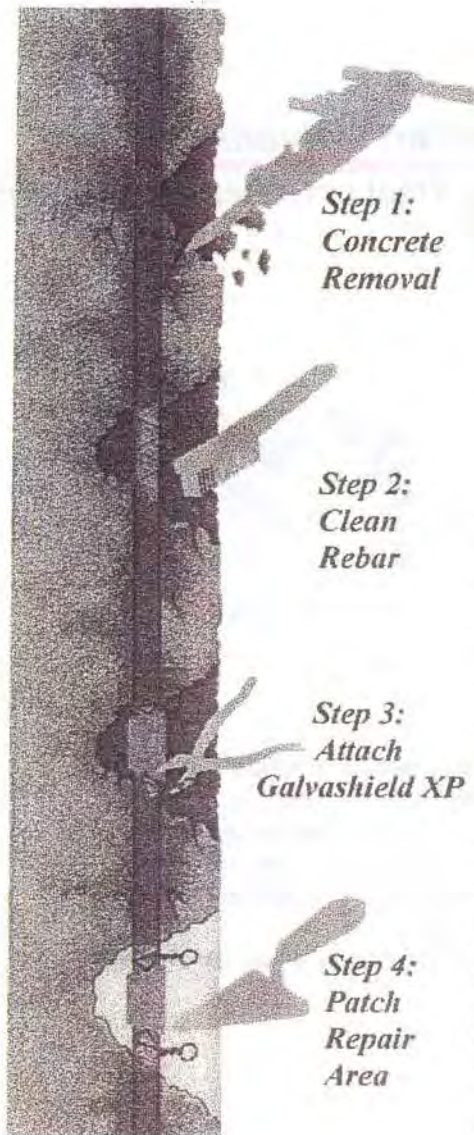

**Step 1:
Concrete
Removal**

**Step 2:
Clean
Rebar**

**Step 3:
Attach
Galvashield XP**

**Step 4:
Patch
Repair
Area**

Service Life

The service life of the Galvashield XP anode is dependent upon a number of factors including reinforcing steel density, concrete conductivity, chloride concentration, humidity conditions, number of anodes installed and their spacing. Greater than 10 years, and up to 20 years life may be expected under normal conditions. Premature consumption may occur, primarily in aggressive situations and/or when insufficient number of anodes are installed.

Installation Instructions

Prior to installing Galvashield XP anodes, the "Installation Instructions" bulletin shall be thoroughly examined for details on the placement and use of Galvashield XP anodes. Anode installation is summarized as follows:

Concrete shall be removed from around and behind the rebar, in accordance with good concrete repair practice. Galvashield XP anodes shall be installed to clean reinforcing steel. Securely fasten the anode to the reinforcing steel using a suitable wire twisting tool to eliminate free movement, and to ensure a good electrical connection. Following the anode installation, the electrical connection between the anode tie wires and the cleaned reinforcing bar should be confirmed with an appropriate meter.

The location and spacing of the anodes shall be as specified by the designer. Typically, the anodes shall be placed around the perimeter of the repair area and spacing shall not exceed 30 inches (750 mm) on center. With the anodes in position the repair can be completed using the appropriate repair materials. Compatible repair materials and bonding agents should be used to ensure maximum performance.

Technical Support

Technical support is available through *Vector Corrosion Technologies*.

Limitations

Galvashield XP anodes have been developed to minimize on-going corrosion activity. Galvashield XP anodes are not intended to address or repair structural damage. Where structural damage exists, consult a structural engineer.

Galvashield XP anodes are a patented technology and guaranteed against defective materials and workmanship, and are sold subject to standard terms and conditions of sale, copies of which may be obtained on request. While Vector Corrosion Technologies endeavors to ensure the information and recommendations it supplies are accurate, it cannot accept any liability arising from use of its products because it has no control over where and how its products are applied.

For Further Information Contact:

Vector Corrosion Technologies

474 Dovercourt Drive
Winnipeg, Manitoba, Canada R3Y 1G4
Phone: (204) 489-6300
Fax: (204) 489-6033
Email: galvashield@vectorgroup.com
Website: www.norcure.com



VECTOR CONSTRUCTION GROUP

Winnipeg, MB	(204) 489-6300	Sioux City, NE	(402) 494-9305
Thunder Bay, ON	(807) 346-4405	Edmonton, AB	(780) 962-6778
Fargo, ND	(701) 280-9697	Toronto Area, ON	(905) 662-4020
Saskatoon, SK	(306) 934-3533	Medina, OH	(330) 723-1177

Appendix B

Locations and Installation Dates

MIDDLESEX-BOLTON PROJECT ACIM089-2(26)
 GALVASHIELD ANODE INSTALLATION DATES AND LOCATIONS FOR ALL BRIDGES

12/06/02

BILL FARLEY

DATE	BRIDGE 43N	BRIDGE 43S	BRIDGE 48N	BRIDGE 48S	BRIDGE 50N
07/02/01				50	PIER 2 TOP CAP REPLACEMENT
07/09/01				63	PIER 1 TOP CAP REPLACEMENT
09/27/01				53	PIER 2 LOWER STEM REPAIR
09/27/01				2	PIER 2 LOWER STEM MONITORING KITS 1,2
09/28/01				36	PIER 1 LOWER STEM REPAIR
09/28/01				1	PIER 1 LOWER STEM MONITORING KITS #4
10/04/01				36	PIER 2 MID STEM REPAIR
10/04/01				31	PIER 1 MID STEM REPAIR
10/11/01				47	PIER 2 UPPER STEM AND LOWER CAP REPAIR
10/11/01				2	PIER 2 UPPER STEM AND LOWER CAP MONITORING KITS 3,4
10/15/01				62	PIER 1 UPPER STEM AND LOWER CAP REPAIR
10/15/01				3	PIER 1 UPPER STEM AND LOWER CAP MONITORING KITS 1,2,3
04/10/02			45		PIER 1 LOWER STEM REPAIR
04/10/02			1		PIER 1 LOWER STEM-MONITORING KITS 1
04/16/02			29		PIER 2 LOWER STEM REPAIR
04/16/02			1		PIER 2 LOWER STEM MONITORING KITS 7
04/19/02			47		PIER 1 MID. TO UPPER STEM REPAIR
04/19/02			2		PIER 1 MID. TO UPPER STEM MONITORING KITS 3,4
04/24/02			25		PIER 2 UPPER STEM REPAIR
04/24/02			2		PIER 2 UPPER STEM MONITORING KITS 5,6
04/30/02			26		PIER 1 LOWER CAP REPAIR
04/30/02			2		PIER 1 LOWER CAP MONITORING KITS 1,2
05/02/02			26		PIER 2 LOWER CAP REPAIR
05/02/02			2		PIER 2 LOWER CAP MONITORING KITS 3,4
05/06/02				14	PIER 2 FOOTING REPAIR
05/24/02	15	PIER 1 CAP-5 PER COLUMN			
05/24/02	15	PIER 2 CAP-5 PER COLUMN			
06/20/02					15 PIER 1 CAP-5 PER COLUMN
06/21/02					15 PIER 2 CAP-5 PER COLUMN
07/11/02			22		PIER 1 TOP CAP REPLACEMENT
07/16/02			25		PIER 2 TOP CAP REPLACEMENT
07/16/02			2		PIER 2 TOP CAP MONITORING KITS 1,2
07/23/02		24	PIER 1 AND 2 STEM REPAIR- FIBER WRAP		
07/25/02	8	PIER 1 AND 2 STEM REPAIR- FIBER WRAP			
10/16/02			28		PIER 2 FOOTING REPAIR
10/25/02			11		PIER 2 LOWER STEM REPAIR
10/29/02			19		PIER 1 LOWER STEM AND FOOTING REPAIR
11/13/02				9	PIER 1 FOOTING REPAIR
11/15/02				21	PIER 1 LOWER STEM REPAIR
TOTALS	38	24	315	430	30

GRAND TOTAL 837

12 KITS

8 KITS

NOTE!!
 BRIDGES 49 NORTH, 49 SOUTH AND 50 SOUTH DID NOT HAVE ANODES INSTALLED
 BRIDGES 43 NORTH AND 43 SOUTH HAD COLUMN REPAIRS DONE AND THEN THEY WERE ALL
 WRAPPED WITH FIBERGLASS AND EPOXY THIS WAS AN ATTEMPT TO SEAL OFF THE COLUMNS
 AS WELL AS MAKE THEM STRONGER

ESTIMATE

BRIDGE 42S

SOUTHEAST SUPPORT
SLOPE SIDE

250
+ 10.26

225 ft
Curb
1.9 Angles

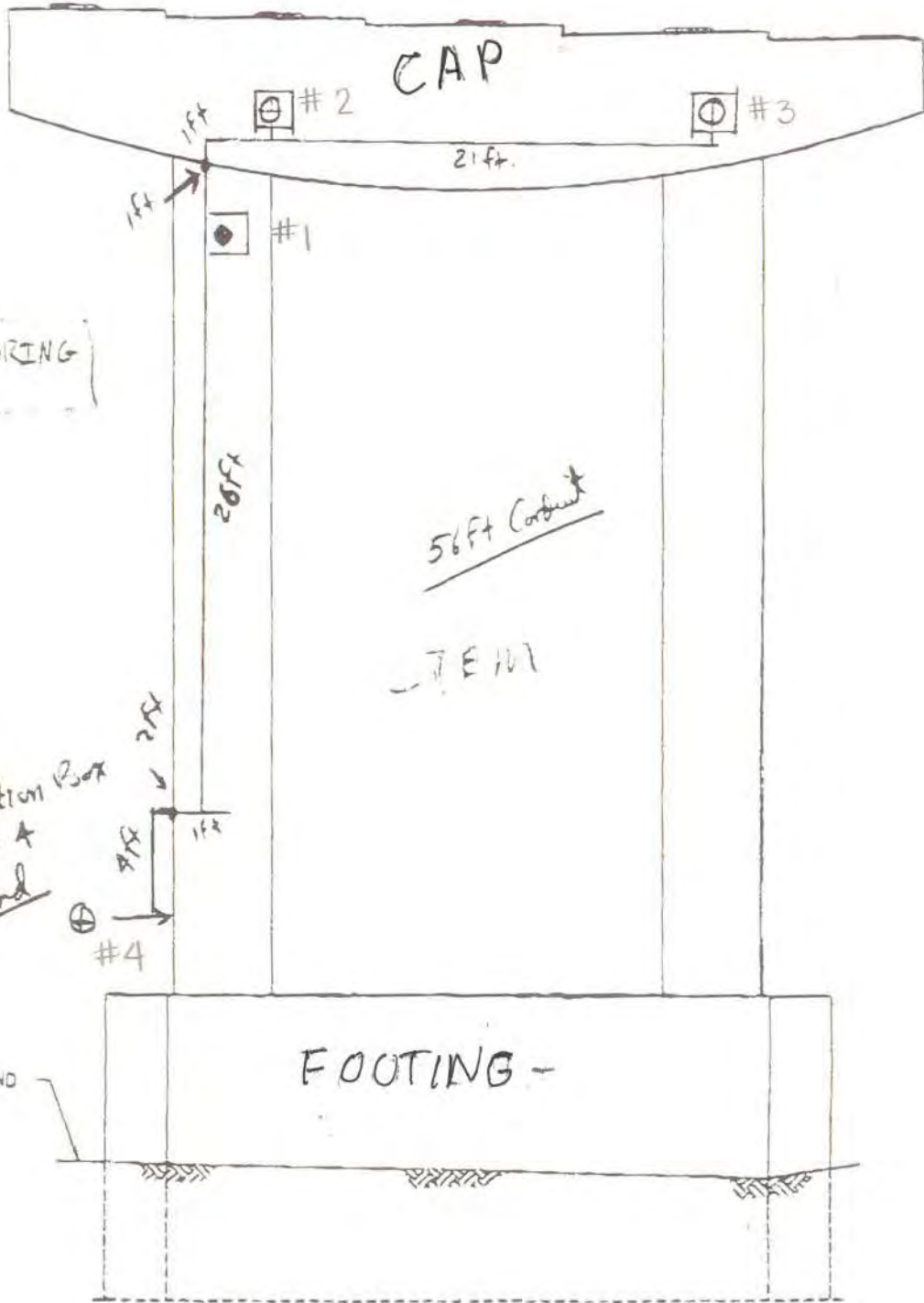

⊕ ⇒ MONITORING KIT

Junction Box
#4
On End

APPROX.
EXIST. GROUND

FOOTING -

(PIER 2 SIDE)
SOUTH SIDE
PIER 1 ELEVATION (PIER A)
SCALE: 3/16" = 1'-0"

BRIDGE #2 S

SOUTHWEST SUPPORT
RIVER SIDE

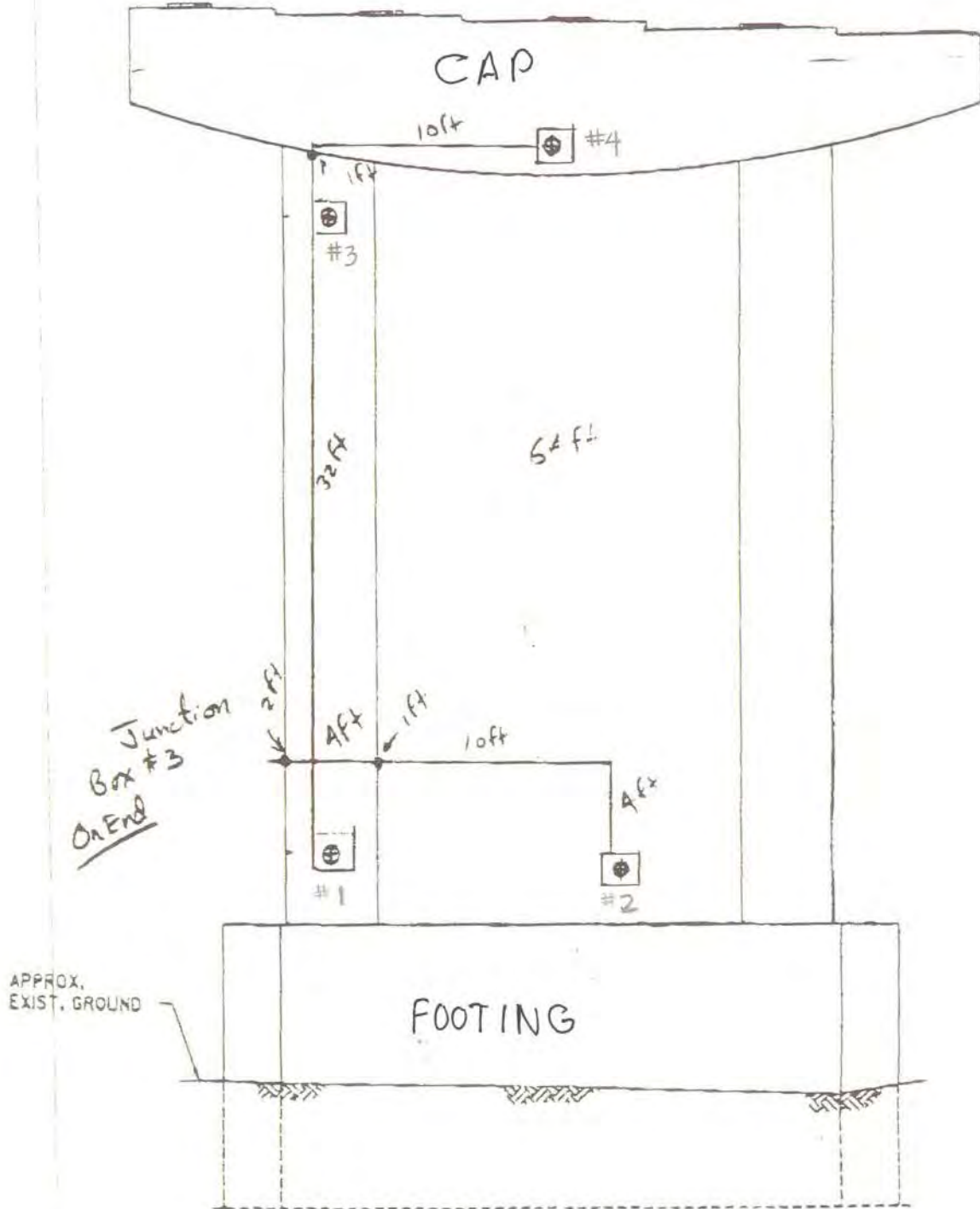

~~PIER 2 SIDE~~
SOUTH SIDE

PIER 2 ELEVATION (PIER C)

SCALE: 3/16" = 1'-0"

BRIDGE 42N

NORTHWEST SUPPORT
RIVER SIDE

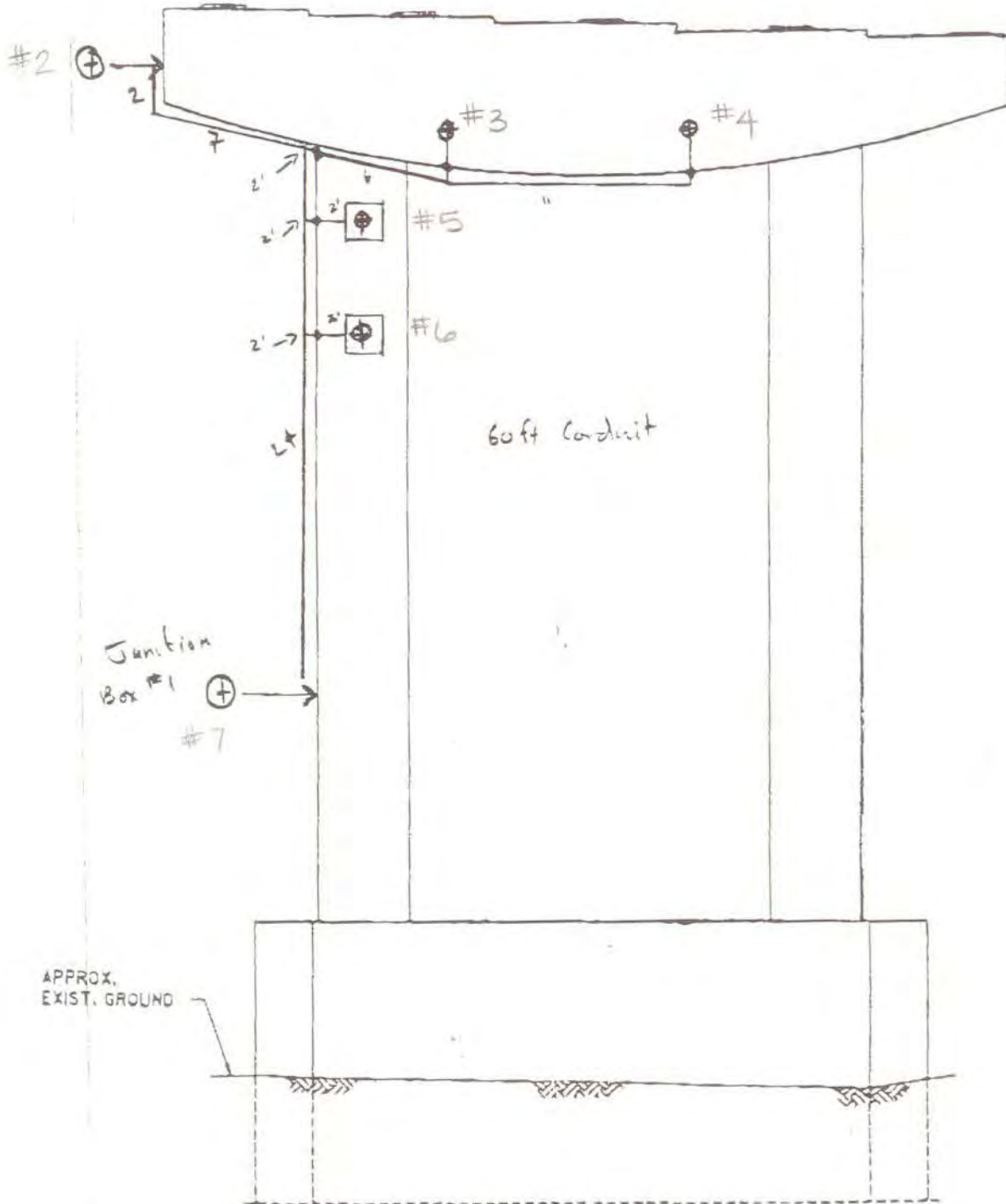

~~(PIER 2 SIDE)~~
SOUTH SIDE
PIER 2 ELEVATION (PIER 0)
SCALE: 3/16" = 1'-0"

BRIDGE 48N

NORTH WEST SUPPORT
SLOPE SIDE

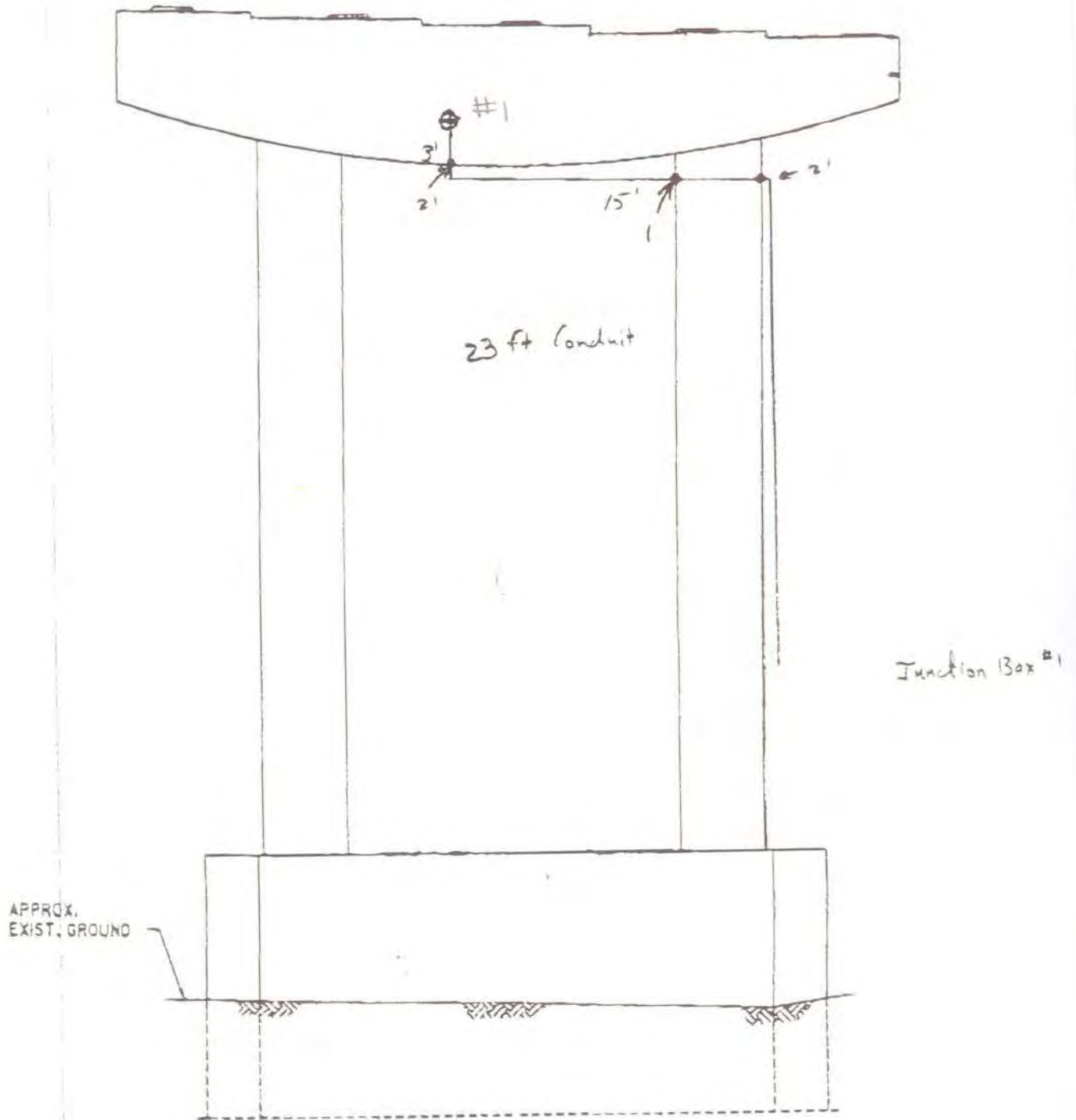

~~(PIER 2 SIDE)~~
NORTH SIDE
PIER 2 ELEVATION (PIER D)
SCALE: 3/16" = 1'-0"

BRIDGE 48 N

NORTH EAST SUPPORT
SLOPE SIDE

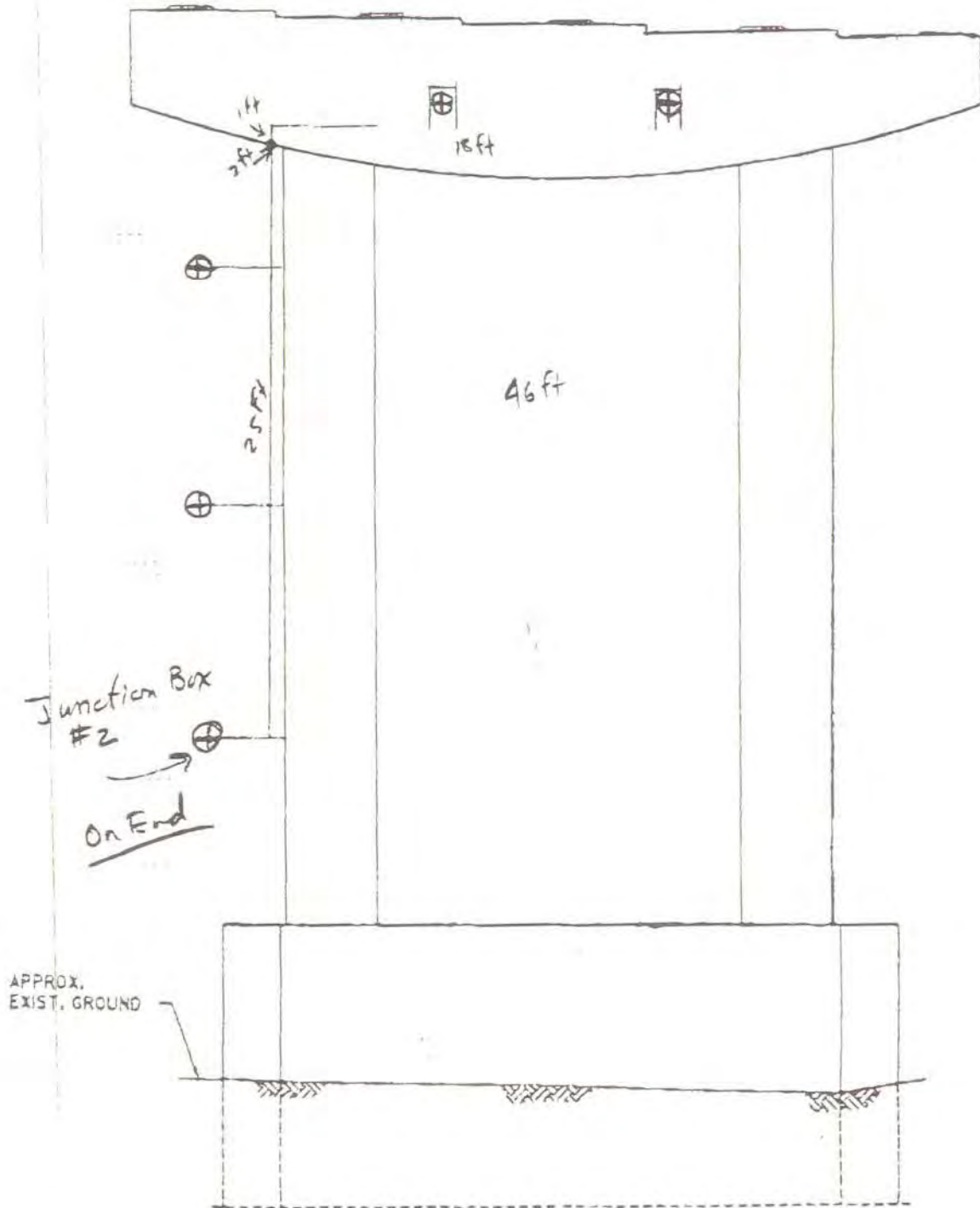

~~(PIER 2 SIDE)~~
SOUTH SIDE
PIER 1 ELEVATION (PIER B)
SCALE: 3/16"=1'-0"

Appendix C

Installation and Monitoring Instructions

GALVASHIELD® XP *Installation Instructions*

The Galvashield® XP anode is designed to mitigate corrosion of reinforcing steel in concrete. In concrete restoration, the Galvashield® XP anode can be used in locations where an interface between the new repair mortar/concrete and the existing chloride contaminated or carbonated concrete creates a high potential for future corrosion (for more information, refer to "Galvashield® XP Theory"). The Galvashield® XP anode is simply tied to the existing reinforcing steel along this interface or around the perimeter of the repair area. For maximum performance, the anodes should be installed as close as practical to the edge of the repair area (within 6 in. or 150mm) while still providing sufficient clearance for the anode to be completely surrounded by the repair mix. Anode spacing shall be as specified by the designer however anode spacing should not exceed 30 inches (750mm) on center. Structures containing heavy reinforcement or exposure to a particularly corrosive environment may require reduced spacing. For additional information, contact Vector.

Installation Procedure

1. As in standard patch repairs, all old/loose concrete should be removed from around and behind the steel reinforcement inside the repair area in accordance with good concrete repair practice. Provide sufficient clearance between the anode and the substrate concrete (minimum of ¾ in. [19mm] or ¼ inch [6mm] larger than the top size aggregate in the repair material, whichever is greater).
2. The exposed rebar in the repair area shall be thoroughly cleaned to bright metal to facilitate a good electrical connection where anodes will be attached. Prior to installation, electrical continuity of the rebar within the repair area should be confirmed with the use of an appropriate meter.

Note: When checking electrical continuity D.C. resistance of 5 Ohms or less is acceptable. Discontinuities can be corrected by wiring the "unconnected" bar to adjacent bars using standard steel tie wire.

3. Securely fasten anode in place with attached tie wires. If the anode is to be tied onto a single bar, or if less than 1 inch (25mm) of concrete cover exists, place anode beneath the bar (away from the surface of the concrete). If sufficient cover exists, the anode may be placed at the intersection between two bars and secured to each clean bar.
4. Once installed, electrical continuity between the anode tie wires and the rebar should be confirmed using an appropriate meter. Maximum D.C. resistance of 5 Ohms.
5. Repair material must have a resistivity below 15,000 ohm-cm. Products with significant polymer modification and/or silica fume content may not be suitable. Similarly, if bonding agents are used, they should have suitable conductivity. Insulating materials such as epoxy bonding agents should not be used.

Note: If rebar coatings are to be used, care should be taken to ensure the anode and tie wires do not become coated or the connection between the anode tie wires and the rebar is not lost.

6. Complete the repair following normal concrete repair procedures, taking care not to create any voids around the anode.

Health and Safety Information

As with all cement based products, contact with water/moisture can release alkalis which may be harmful to exposed skin. Avoid contact with skin. Wear suitable gloves and other personal protective equipment in accordance with standard practices for handling cement based materials. Additional safety information is provided in the Galvashield® XP Material Safety Data Sheet (MSDS).

Storage Instructions

Avoid extremes of temperature and humidity. Anodes are not particularly vulnerable to storage conditions but should be installed within 1 year.



Vector Corrosion Technologies

474 Dovercourt Drive, Winnipeg, MB Canada R3Y 1G4

Phone: (204) 489-6300, Fax: (204) 489-6033

Email: galvashield@vectorgroup.com Internet: www.vector-corrosion.com

Galvashield XP *Monitoring Kit*

Installation Instructions

As in standard patch repairs, concrete should be removed from around and behind the steel reinforcement in accordance with good concrete repair practice.

Clean all exposed reinforcement inside the repair area thoroughly to facilitate a good electrical connection.

Galvashield XP anodes should be placed inside the patch area, adjacent to the repair edge. The anodes should be attached directly to the steel using the cable ties (provided) and should be positioned in such a way that after patching, concrete cover over the anode is consistent with the surrounding areas.

The cathode connection (to reinforcing steel) is made by attaching the stripped end of a black copper lead to clean reinforcing steel using the hose clamp (provided). Continuity is checked after installation with an appropriate meter. By touching one multimeter lead wire to the reinforcing steel and the other to the switch contact connected to the cathode wire (black), the reading should be less than 2 ohms (Ω). If not, tighten hose. The entire connection must be covered in silicone or epoxy (NOT provided) to prevent loss of continuity due to corrosion at the interface between the copper and the steel.

Place the junction box away from traffic or other possible causes of damage or disturbance. Secure the box with tape found on the underside of the box, or by other means of anchoring or tying. The wires (black & red) leading out of the patch area to the junction box are to be placed where they will not interfere with repair completion, the excess wire may be coiled up and placed neatly out of the patch area. When convenient, the switch (provided) must be connected to the black and red leads inside the junction box.

When installing monitored anodes in conjunction with other anodes, the spacing and location is as stated in the installation instructions for the Galvashield XP and/or described in the specification.

Complete the repair using a suitable cementitious based, repair mortar or concrete (preferably not polymer or latex modified). If bonding agents or rebar primers are to be used, care should be taken to ensure that the anode does not become coated, as this may inhibit its performance.

Current Measurement

Current is measured with the same meter as when measuring continuity. Be certain the range is set for microamps (μA) or milliamps (mA) when measuring DC current. Connect the multimeter leads to the two contacts of the switch. When the switch is ON the reading will be zero. To correctly take a reading, turn the switch OFF and record the current measurement. Do not forget to return the switch to the ON position.

Health and Safety Information and **Storage Instructions** are consistent with Galvashield XP Installation Instructions.

Norcure Chloride Removal Systems Inc.

474 Dovercourt Drive
Winnipeg, Manitoba, Canada
R3Y 1G4

Phone: (204) 489-9633
Fax: (204) 489-6033
Email: galvashield@norcure.com
Web: www.norcure.com





GALVASHIELD® XP *Monitoring Kit Instructions*

Each Galvashield® XP Monitoring Kit contains:

- Galvashield® XP anode hard-wired to insulated red electrical lead (3m long)
- Insulated black electrical lead (3m long)
- Switch with crimp-on connectors
- Weather-proof junction box
- Hose clamp

Prior to installation, as in all standard patch repairs, concrete should be removed from around and behind the steel reinforcement in accordance with good concrete repair practice. Clean all exposed reinforcement inside the repair area appropriately to facilitate a good electrical connection. Galvashield® XP anodes should be placed inside the patch area, adjacent to the repair edge. The anodes should be attached directly to the steel using plastic cable ties (NOT provided) and should be positioned in such a way that after patching, concrete cover over the anode is consistent with the surrounding areas.

The cathode connection (to reinforcing steel) is made by attaching the stripped end of the black copper lead to clean reinforcing steel (near the location of the anode) using the hose clamp. Continuity is checked after installation with an appropriate multi-meter. By touching one meter lead to the reinforcing steel and the other to the switch contact connected to the cathode wire (black), the DC resistance should be less than 5 ohm (Ω). If not, tighten or reposition hose clamp. Finally, the entire connection must be covered completely in silicone or epoxy (NOT provided) to prevent corrosion between the copper wire and the steel clamp. Place the junction box away from traffic or other possible causes of damage or disturbance. Secure the box with the adhesive tape found on the underside of the box or by another means. The two wires (black & red) leading out of the patch area to the junction box may be better protected by placing in a saw-cut groove or plastic conduit. However, excess wire may be coiled up and placed neatly outside of the patch area until the repair material has been placed. When convenient, the switch (provided) must be connected to the black and red leads inside the junction box.

When installing monitored anodes in conjunction with unmonitored anodes, the spacing and location is as stated in the specification. Compatible repair materials must have a resistivity below 15,000 ohm-cm. Products with significant polymer modification and/or silica fume content may not be suitable. Similarly, if bonding agents are used, they should have suitable conductivity. Insulating materials such as epoxy bonding agents should not be used. If rebar coatings are to be used, care should be taken to ensure the anode and tie wires do not become coated or the connection between the anode tie wires and the rebar is not lost. Complete the repair following normal concrete repair procedures, taking care not to create any voids around the anode.

Current Measurement

Current is measured with the same meter as when measuring continuity. Be certain the range is set for microamps (μ A) or milliamps (mA) when measuring DC current. Connect the multimeter leads to the two contacts of the switch. When the switch is ON the reading will be zero. To correctly take a reading, turn the switch OFF and record the current measurement (Do not forget to return the switch to ON).

Health and Safety Information and **Storage Instructions** are consistent with Galvashield® XP Installation Instructions.



Vector Corrosion Technologies

474 Dovercourt Drive, Winnipeg, MB Canada R3Y 1G4

Phone: (204) 489-6300, Fax: (204) 489-6033

Email: info@vector-corrosion.com Internet: www.vector-corrosion.com

GALVASHIELD® XP

Monitoring Performance

The Galvashield® XP embedded galvanic anode is comprised of a sacrificial zinc core, surrounded by a highly alkaline mortar matrix. The anode has been designed as a simple method of providing galvanic corrosion protection to steel embedded in concrete. By corroding sacrificially, the zinc core of the anode throws out an electric current into the local reinforcing steel, thereby reducing its corrosion. The electrochemical nature of this type of galvanic protection means that the operation of the anode can be monitored, and evaluated. In order to most effectively monitor the performance of a Galvashield® anode it is advisable to install a "Galvashield® Monitoring Kit". Please refer to the sheet entitled "Galvashield® Monitoring Instructions" for further detail on how this installation differs from a typical Galvashield® application.

The Galvashield® monitoring kit, is designed to be a simple device enabling instant feedback on the operation of the anode. It can be installed in a field environment by non-technical personnel, with a minimum amount of effort. It provides a tangible method whereby owners and engineers can verify that the anode is functioning properly. The anode's performance may be monitored over time, revealing its changing performance through external influences (i.e. environmental changes). The collected information can also be used to estimate the approximate service life of the anode. The same factors which affect corrosion of the reinforcing steel will affect the rate of consumption of the anode's zinc core. Therefore in warm/humid seasons the anode will output a higher level of current than during cold/dry seasons. Other factors affecting service life include the amount of active corrosion and the density of reinforcing steel present in the structure.

The two key measurements that can be obtained are voltage output and current output of the anode. The voltage is a measurement of the electrical potential difference between the reinforcing steel and the zinc core of the anode. It is also a measurement of the ability of the anode to "throw" an electric current into the surrounding steel reinforcement. The second, and more useful piece of information is the current output. By measuring the electric current that flows between the anode and the reinforcing steel, one is observing the rate of corrosion of Galvashield®'s sacrificial core. The current flow will fluctuate according to the factors mentioned in the previous paragraph. Therefore a number of readings collected over a period of time and averaged will yield a more representative number. Faraday's Law relates the current output of the anode and its service life, and allows us to approximately estimate the service life of the anode in a given application. The anode's life is inversely proportional to the current flow according to,

$$\text{Life (years)} = 5800 / \text{Current Output } (\mu\text{A})$$

The steps below outline the method of utilizing the Galvashield® Monitoring Kit:

1. Open monitoring box by removing the four holding screws.
2. Switch on digital volt meter (DVM) and select DC Current (μA or mA ranges).
3. Turn switch "off" in junction box and record the current across the terminals of the switch.
4. Adjust meter to select DC mV.
5. Record the voltage across the switch terminals.
6. Turn switch "on", close and re-seal monitoring box.

More complex measurements are possible, and can be co-ordinated with the installation of a monitoring kit to reveal the effect of the Galvashield® anode on corrosion in the reinforcing steel. These measurements require an involved program of testing including half-cell measurements or embedded reference cells, and should be undertaken with the guidance of engineers specializing in corrosion testing on reinforced concrete structures.



Vector Corrosion Technologies

474 Dovercourt Drive, Winnipeg, MB Canada R3Y 1G4

Phone: (204) 489-6300, Fax: (204) 489-6033

Email: info@vector-corrosion.com Internet: www.vector-corrosion.com

Appendix D

Cost Information

State of Vermont
 Agency of Transportation
CHANGE OF DESIGN or CONSTRUCTION
 (Executed in Duplicate)

Change Order No. 17

Date: _____

Project Name Middlesex-Bolton

Project Number: AC IM 089-2(26)

Change in Design <u>X</u>	Supplementary Agreement <u>X</u>	Extra Work Order <u>X</u>	Contract ID Number: 00101301
---------------------------	----------------------------------	---------------------------	------------------------------

TO: Winterset, Inc. – You are hereby notified to perform the following work in accordance with the Provisions of your Contract with the Agency of Transportation dated 10/20/2000 and as modified by this document.

Revision:

Add the experimental Item of Galvashield XP Sacrificial Anodes and associated test/monitoring kits.

Necessity for Revision:

This is a Category II Experiment Project, to aid in the development of systems to extend concrete substructure service life.

This change order received verbal approval from, Project Manager, on 06/25/01.

This change order received verbal approval from, Federal Highway Administrator, on 12/10/02.

New Items not in Contract:

ITEM 900.08 Extra Work Order #8 @ Twenty Seven Thousand Seven Hundred Nineteen Dollars and Ninety Six Cents (\$27,719.96) Per Lump Sum.
 Payment for this item will be lump sum to furnish one thousand two hundred sixty (1260) Galvashield XP Anodes and forty (40) Galvashield XP Monitoring Kits; this includes materials, shipping and handling. All anodes and test kits not used on his project will be the property of the State of Vermont and will go to the Agency of Transportation's Materials and Research Division.

ITEM 900.03 Extra Work Order #3 @ One Dollar and Twenty Five Cents (\$1.25) Each.
 Payment for this item will be per each for the installation of the Galvashield XP Anodes, to include all equipment, tools, labor, incidentals and mobilization necessary to complete the work.

ITEM 900.04 Extra Work Order #4 @ Thirty Five Dollars and Zero Cents (\$35.00) Each.
 Payment for this item will be per each for the installation of the Galvashield XP Monitoring Kits, to include all equipment, tools, labor, incidentals and mobilization necessary to complete the work.

ITEM 900.09 Extra Work Order #9 @ Seven Thousand Nine Hundred Eighty Seven Dollars and Eighty Three Cents (\$7,987.83) Per Lump Sum.
 Payment for this item will be lump sum for the installation of the conduit, wiring, and four (4) weatherproof control boxes required for access to the Galvashield XP Monitoring Kits. This lump sum price will include all materials, equipment, tools, labor, incidentals and mobilization necessary to complete the work.

QUANTITY AND COSTS AS PER PLANS AND/OR REVISIONS							
Category: see below							
Item No.	Item Name	Unit	Unit Price	Original Quantity	Revised Quantity	Original Cost	Revised Cost
BRIDGE #43N							
900.08	Extra Work Order #8	LS	\$27,719.96	0	0.05	0	\$1,386.00
900.03	Extra Work Order #3	EA	\$1.25	0	38	0	\$47.50

BRIDGE #43S							
900.08	Extra Work Order #8	LS	\$27,719.96	0	0.05	0	\$1,386.00
900.03	Extra Work Order #3	EA	\$1.25	0	24	0	\$30.00
BRIDGE #48N							
900.08	Extra Work Order #8	LS	\$27,719.96	0	0.35	0	\$9,701.98
900.03	Extra Work Order #3	EA	\$1.25	0	315	0	\$393.75
900.04	Extra Work Order #4	EA	\$35.00	0	12	0	\$420.00
900.09	Extra Work Order #9	LS	\$7,246.62	0	0.5	0	\$3,623.31
BRIDGE #48S							
900.08	Extra Work Order #8	LS	\$27,719.96	0	0.50	0	\$13,859.98
900.03	Extra Work Order #3	EA	\$1.25	0	430	0	\$537.50
900.04	Extra Work Order #4	EA	\$35.00	0	8	0	\$280.00
900.09	Extra Work Order #9	LS	\$7,246.62	0	0.5	0	\$3,623.31
BRIDGE #50N							
900.08	Extra Work Order #8	LS	\$27,719.96	0	0.05	0	\$1,386.00
900.03	Extra Work Order #3	EA	\$1.25	0	32	0	\$40.00
						Totals	\$36,715.33

Additional Cost: \$35,987.83

Contract Extension Granted: No

Working Days Added: N/A

Change Order Approved: _____
Contractor

Signature of Authorized Individual

Recommended for Approval:

		Nathan R. Danforth	David J. Scott
Resident Engineer	Regional Construction Engineer	Construction Engineer	Director of Project Development
Date:	Date:	Date:	Date:

Approved for Federal Participation

Division Administrator, FHWA

Date: _____

Original Contract Amount	Change in Design Total to Date	Revised Contract Amount	Percent of Original Contract
\$	\$	\$	

Appendix E

Photographs



East Piers



West Piers