

VERMONT AGENCY OF TRANSPORTATION GUIDELINES FOR PEDESTRIAN CROSSING TREATMENTS

January 2015 Update



Table of Contents

List of Figures	3
Criteria at a Glance	4
1.0 Introduction.....	6
1.1 Use of Guideline:	6
2.0 Marked Crosswalks at Intersections.....	7
2.1 Signalized Intersections:.....	7
2.1.1 <i>Criteria for installation:</i>	7
2.1.2 <i>No parking zone:</i>	7
2.1.3 <i>Pedestrian Warning Signs:</i>	8
2.2 Unsignalized Intersections –Controlled Approaches:	8
2.2.1 <i>Criteria for installation:</i>	9
2.2.2 <i>Installation of Stop or Yield Line:</i>	9
2.2.3 <i>No parking zone:</i>	9
2.2.4 <i>Pedestrian Warning Signs:</i>	9
2.3 Unsignalized Intersections – Roundabout:	10
2.3.1 <i>Criteria for installation:</i>	10
2.3.2 <i>No parking zone:</i>	10
2.3.3 <i>Pedestrian Warning Signs:</i>	11
2.4 Unsignalized Intersections – Uncontrolled Approaches:	12
2.4.1 <i>Criteria for installation:</i>	12
2.4.2 <i>No parking zone:</i>	13
2.4.3 <i>Pedestrian Warning Signs:</i>	13
3.0 Marked Crosswalks at Mid-Block Locations.....	14
3.1 School Crossings:	14
3.1.1 <i>Criteria for installation:</i>	14
3.1.2 <i>No parking zone:</i>	15
3.1.3 <i>School Crossing Signs:</i>	15
3.2 Non-School Crossings:	16
3.2.1 <i>Criteria for installation:</i>	16
3.2.2 <i>No parking zone:</i>	18
3.2.3 <i>Pedestrian Warning Signs:</i>	18
3.3 Stopping Sight Distance Chart:	18
4.0 Unmarked Crossings	19
4.1 Unmarked Crossings.....	19
5.0 Design of Marked Crosswalks	20
5.1 Pavement Markings:.....	20
5.2 Other Considerations:	21
5.2.1 <i>ADA Compliance:</i>	21
5.2.2 <i>Shared-Use Paths:</i>	21
5.2.3 <i>Colored and Textured pavement:</i>	21
5.2.4 <i>Use of Fluorescent Yellow-Green Signs:</i>	21
5.3 Enhancements to marked crosswalks at uncontrolled locations.....	22
5.3.1 <i>In-street Pedestrian Sign</i>	25
5.3.2 <i>Pedestrian Refuge Island</i>	26

5.3.3	Advanced Yield Line.....	28
5.3.4	RRFBs (Rectangular Rapid Flashing Beacons).....	30
5.3.5	Pedestrian Hybrid Beacon.....	32
5.3.6	Bulbouts.....	33
6.0	Vermont Law.....	34
7.0	MUTCD Support and Guidance.....	36
8.0	Resources and References	40

List of Figures

Figure 1:	Traffic Signal Controlled Intersections.....	7
Figure 2:	Stop or Yield controlled approach	8
Figure 3:	Roundabout approach.....	10
Figure 4:	Uncontrolled intersection approach	12
Figure 5:	School Crossing	14
Figure 6:	Mid-Block Crossing.....	16
Figure 7:	Stopping Sight Distances.....	18
Figure 8:	Unmarked Crossings.....	19
Figure 9:	Allowable crosswalk marking patterns.....	20
Figure 10:	Appropriateness of Marked Crosswalks.....	23
Figure 11:	Crosswalk Enhancement Options to Consider.....	24
Figure 12:	Pedestrian Refuge Island	27
Figure 13:	Advance Yield Line	28
Figure 14:	Mid-block Bulbout Example.....	33

Appendices

Appendix A – FHWA Memo on Interim Approval of RRFBs

Criteria at a Glance

For each of the items below, all of the conditions mentioned should be present.

All Crosswalks:

- Sidewalks and curb ramps with detectable warning surfaces on each end of the crossing, or paved shoulder 3-6 feet wide with no parking or other vehicular conflicts. (Wider shoulders may allow for parking activity, unless within an established no-parking zone.)

Signalized approaches:

- Pedestrian signal heads if exclusive pedestrian signal phase, or adequate visibility to vehicular signal heads if concurrent pedestrian phase
- Signal is timed to allow adequate pedestrian crossing time
- No parking for 30 feet on approach to crosswalk

Stop controlled approaches:

- Pedestrian has right of way by law if there are sidewalks on both sides, whether the crosswalk is marked or not. Crosswalk may be marked to prevent stopped vehicles from obstructing pedestrian crossing path or to remind turning vehicles to yield if engineering judgment indicates that vehicle/pedestrian conflicts are likely.

Uncontrolled approaches (intersection or mid-block):

- Speed limit 40 mph or less
- Adequate sight distance from all vehicular approaches to both ends of the crossing

Posted Speed (mph)	Required Sight Distance (feet) *
25	155
30	200
35	250
40	305

**downgrades require longer stopping distances*

- No other crosswalk within 200 ft
- Vehicle volume exceeds 3000 vehicles per day (both directions combined)
- Pedestrian crossing volume exceeds 20 per hour in the highest pedestrian hour of the day (Elementary school age – 12 and under and elderly pedestrians – over 60 - count as 2 each)
- No parking within 20 feet of crosswalk (unless crosswalk is located mid-block with bulbouts - see section 5.3.6)

- In densely developed areas, such as a village center, one crosswalk may be used to channelize pedestrians to the safest or most desirable crossing location. For this scenario, there is no minimum pedestrian or vehicular volume if all other criteria are met and engineering judgment indicates that providing the crosswalk may increase the safety of pedestrians (see 3.2.1 for further guidance on this topic.)

1.0 Introduction

1.1 Use of Guideline:

The purpose of this guideline is to ensure that pedestrian crossings are treated consistently throughout the state, on both state highways and local roads, by providing guidance on the location of marked and unmarked crossings, and the associated pavement markings and signs.

This guideline is intended to supplement the Manual on Uniform Traffic Control Devices (MUTCD). Conflicts between the two documents should defer to the latest edition of the MUTCD. References to sections of the MUTCD in this guideline correspond to the 2009 Edition.

This guideline is also intended to incorporate Vermont state law where applicable. Conflicts between this guideline and the latest statutes should defer to the statute. References in this guideline correspond to the 2013 Motor Vehicle Laws of Vermont.

Not all situations can be adequately addressed in this guideline; therefore engineering judgment must be used at all times.

The Vermont Pedestrian and Bicycle Facility Planning and Design Manual, published by VTrans, also contains valuable information about crosswalk design. Included in that manual are recommendations on making pedestrian facilities accessible to all users and meeting Americans with Disabilities Act (ADA) requirements.

Prior to the marking of pedestrian crosswalks on the state route system (via a Section 1111 permit from the VTrans Utilities and Permits section, or through other means,) the proposed crosswalk location must be reviewed to ensure that it conforms to this guideline, the MUTCD, and state statutes.

Crosswalk markings shall only be installed and/or maintained after receiving written approval from the appropriate governing entity: the Agency of Transportation in the case of state highways, Select Board in the case of town highways, or legislative body of a city in the case of city streets.

2.0 Marked Crosswalks at Intersections

2.1 Signalized Intersections:

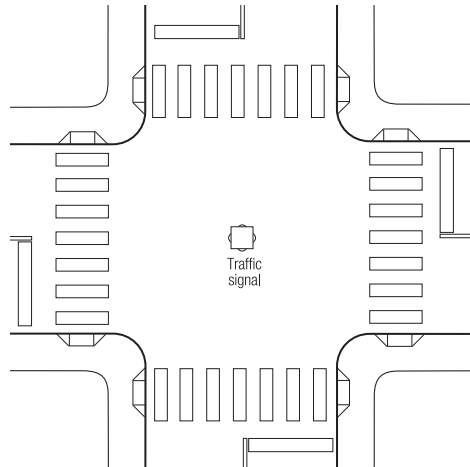

Figure 1: Traffic Signal Controlled Intersections

2.1.1 Criteria for installation:

Exclusive or Concurrent Pedestrian Phase:

Intersections with a traffic signal timed for concurrent or exclusive pedestrian movements should have crosswalks applied across the roadway approaches that have sidewalks present on either side of the intended crossing. Crosswalks should not be installed in the absence of sidewalks unless adequate shoulders exist for use by pedestrians. The determination of adequate shoulder should be based upon an assessment of traffic volumes, adjacent land use patterns and other site specific conditions.

No pedestrian timing:

Intersections with a traffic signal which is not timed to accommodate concurrent or exclusive pedestrian movements, or have traffic signal heads that cannot be seen by the pedestrian, shall not have crosswalks applied on the roadway approaches which might be used by the pedestrian.

2.1.2 No parking zone:

In accordance with state law, parking spaces shall not be marked within 20 feet of a marked crosswalk at an intersection, as measured by the gap between the parking space and the closest crosswalk marking. The MUTCD recommends a 30 feet minimum no parking zone on the approach to crosswalks marked at signalized intersections. On state highways, VTrans Standard E-193 requires a 30 feet minimum no parking zone in advance of crosswalks at signalized intersections.

2.1.3 Pedestrian Warning Signs:

In accordance with the MUTCD, there shall be no pedestrian crossing signs installed at the marked crosswalks where traffic movement is controlled, nor shall advance pedestrian warning signs be installed on the approaches to a signalized intersection.

At intersections where there is a high volume of turning vehicles and the pedestrian phase is concurrent with through movements, a regulatory R10-15 “turning vehicles yield to pedestrians” sign may be used to remind drivers to yield to pedestrians.



2.2 Unsignalized Intersections – Stop or Yield Sign Controlled Approaches:

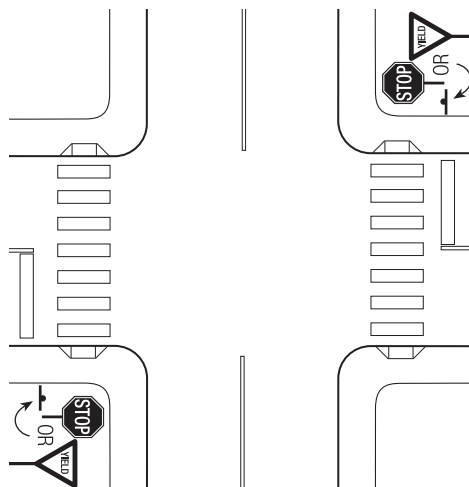

Figure 2: Stop or Yield controlled approach

2.2.1 Criteria for installation:

A crosswalk may be placed across an approach controlled by a stop or yield sign if a sidewalk exists on both sides of the roadway approach controlled by the stop or yield sign. Crosswalks should not be installed in the absence of sidewalks unless adequate shoulders exist for use by pedestrians. The determination of adequate shoulder should be based upon an assessment of traffic volumes, adjacent land use patterns and other site specific conditions. The shoulder shall be a minimum of three feet wide, and a maximum of six feet wide (in order to minimize potential conflicts with parking activities.)

In general, installation of 'parallel' crosswalks across the throat of driveways or minor side roads is not recommended unless there is a high potential for vehicle/pedestrian conflict that will be mitigated by a marked crosswalk.

2.2.2 Installation of Stop or Yield Line:

When a crosswalk is installed at a stop or yield controlled approach, a stop or yield line should also be installed. In accordance with the MUTCD, stop or yield lines should be marked a minimum of 4 feet in advance of the nearest crosswalk line, as measured by the gap between the stop bar and the closest crosswalk marking.

2.2.3 No parking zone:

In accordance with state law, parking spaces shall not be marked within 20 feet of the marked crosswalk, as measured by the gap between the parking space and the closest crosswalk marking.

2.2.4 Pedestrian Warning Signs:

There shall be no pedestrian crossing signs installed at the marked crosswalks nor shall advance pedestrian warning signs be installed on the stop or yield controlled approaches to an intersection.

2.3 Unsignalized Intersections – Roundabout:

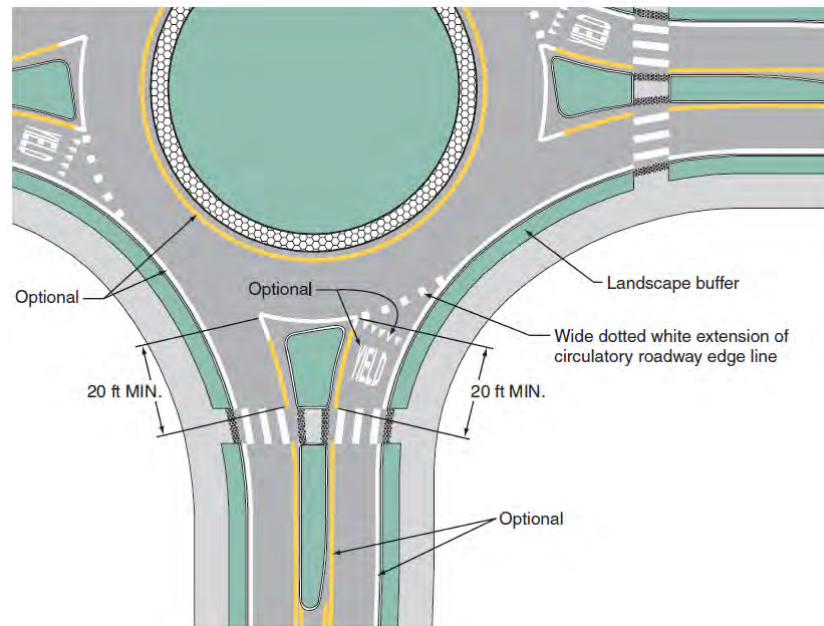

Figure 3: Roundabout approach

2.3.1 Criteria for installation:

A crosswalk may be placed across a roundabout approach if a sidewalk exists on both sides of the approach. Crosswalks should not be installed in the absence of sidewalks unless adequate shoulders exist for use by pedestrians. The determination of adequate shoulder should be based upon an assessment of traffic volumes, adjacent land use patterns and other site specific conditions. The shoulder shall be a minimum of three feet wide, and a maximum of six feet wide (in order to minimize potential conflicts with parking activities.)

In accordance with the MUTCD, where crosswalks are marked on roundabout approaches, they should be marked a minimum of 20 feet in advance of the edge of the circulating lane.

2.3.2 No parking zone:

In accordance with state law, parking spaces shall not be marked within 20 feet of the marked crosswalk, as measured by the gap between the parking space and the closest crosswalk marking.

2.3.3 *Pedestrian Warning Signs:*

Pedestrian warning signs (W11-2 with downward arrow plaque W16-7P) shall be installed at each end of the crosswalk location. At either end, the sign should be placed in advance of the crosswalk from the perspective of the driver in the adjacent travel lane, facing the driver.

Advance pedestrian warning signs (W11-2) with supplemental plaques with the legend "AHEAD" (W16-9P) or "XXX FEET" (W16-2P or W16-2aP) may be installed in advance of the crosswalk. Advance warning signs are not typically used in urban areas where pedestrian activity is an expected feature of the driving environment.

2.4 Unsignalized Intersections – Uncontrolled Approaches:

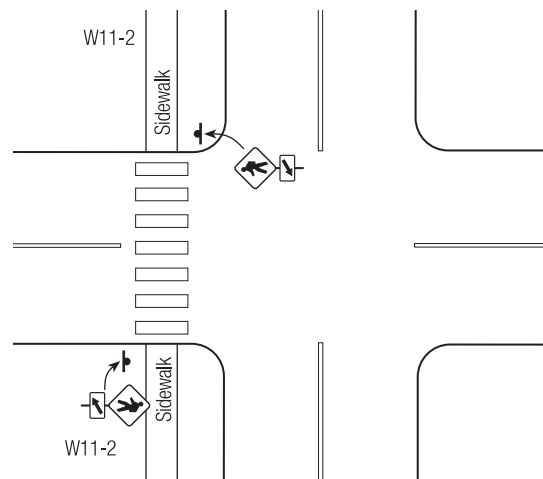

Figure 4: Uncontrolled intersection approach

2.4.1 Criteria for installation:

A crosswalk should not be installed at an intersection on a roadway approach that is not regulated by a traffic signal, a stop sign, or a yield sign unless all of the following criteria are met (unless supported by other factors using engineering judgment:)

1. The speed limit is 40 mph or less;
2. There are 20 or more pedestrians using the crossing per hour during the highest pedestrian volume hour (elementary school age and elderly pedestrians count as 2 each);
3. The AADT (annual average daily traffic) for the roadway (both directions combined) exceeds 3000 vehicles per day;
4. There is a sidewalk or adequate shoulder for use by pedestrians. The determination of adequate shoulder should be based upon an assessment of traffic volumes, adjacent land use patterns and other site specific conditions. The shoulder shall be a minimum of three feet wide, and a maximum of six feet wide (in order to minimize potential conflicts with parking activities.)
5. There is not another crosswalk across the same roadway within 200 feet of the intersection;
6. Adequate sight distance (equal to or exceeding the stopping sight distance for the posted speed) is available in both directions. At a minimum, a driver must

be able to see either the crosswalk or the pedestrian warning sign. It is recommended that sight distance be measured from the driver's perspective to the outer edges of the traveled lanes, to ensure that an approaching driver can see a pedestrian at any point on the crosswalk within the traveled way.

When a proposed crosswalk is associated with a new development, change in land use, or new pedestrian facilities, an engineering study may be used to predict whether these criteria will be met once the development or facility has been constructed.

Crosswalks at uncontrolled locations should not be marked on 3 or 4 lane roadways with AADT greater than 9,000 vehicles per day unless other crosswalk enhancements, such as pedestrian refuge islands, advanced yield lines, or rectangular rapid flashing beacons are included, and an engineering study concludes that pedestrian safety will be enhanced. See section 5.3 for more information about crosswalk enhancements.

2.4.2 No parking zone:

In accordance with state law, parking spaces shall not be marked within 20 feet of a marked crosswalk at an intersection, as measured by the gap between the parking space and the closest crosswalk marking.

2.4.3 Pedestrian Warning Signs:

Pedestrian warning signs (W11-2 with downward arrow plaque W16-7P) shall be installed at each end of the crosswalk location. At either end, the sign should be placed in advance of the crosswalk from the perspective of the driver in the adjacent travel lane, facing the driver.

Advance pedestrian warning signs (W11-2) with supplemental plaques with the legend "AHEAD" (W16-9P) or "XXX FEET" (W16-2P or W16-2aP) may be installed in advance of the crosswalk in order to give drivers additional advance notice of the crosswalk. Advance warning signs are not typically used in urban areas where pedestrian activity is an expected feature of the driving environment.

At locations along an officially established and recognized route to school, School symbol signs (S1-1) may be used in place of the Pedestrian Warning signs (W11-2).

3.0 Marked Crosswalks at Mid-Block Locations

3.1 School Crossings:

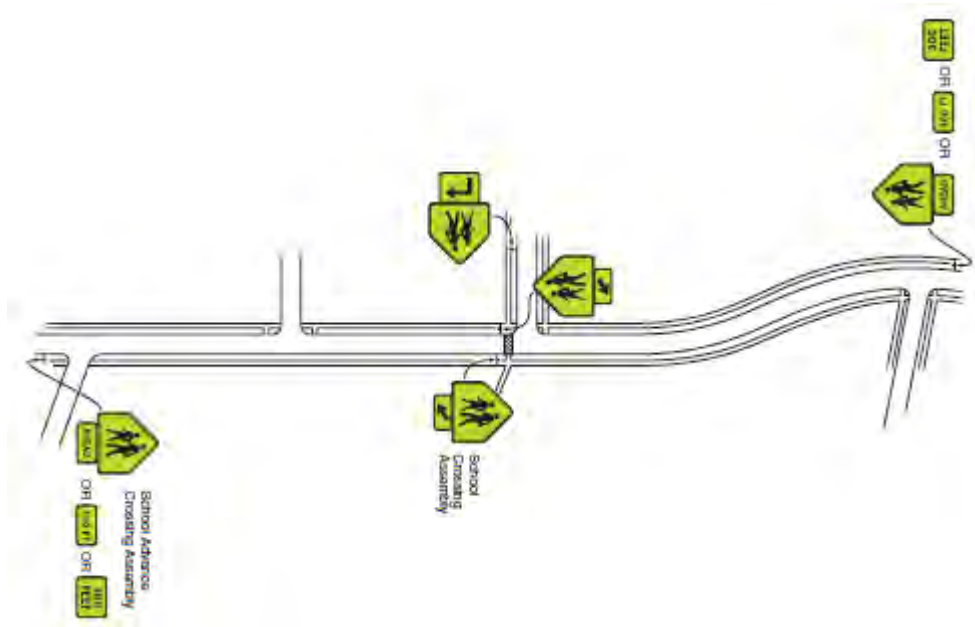

Figure 5: School Crossing

Crosswalks should be marked at crossing locations on established routes to a school (if the school has established a school route plan) where there is substantial conflict between vehicles and students, or where students would not otherwise know the proper place to cross.

3.1.1 Criteria for installation:

All of the following criteria should be met prior to installing a crosswalk (unless supported by other factors using engineering judgment:)

1. The speed limit is 40 mph or less;
2. There is a sidewalk or adequate shoulder for use by pedestrians. The determination of adequate shoulder should be based upon an assessment of traffic volumes, adjacent land use patterns and other site specific conditions.

The shoulder shall be a minimum of three feet wide, and a maximum of six feet wide (in order to minimize potential conflicts with parking activities.)

3. There is not another crosswalk across the same roadway within 200 feet;
4. Adequate sight distance (equal to or exceeding the stopping sight distance for the posted speed) is available in both directions. At a minimum, a driver must be able to see either the crosswalk or the school crossing sign. It is recommended that sight distance be measured from the driver's perspective to the outer edges of the traveled lanes, to ensure that an approaching driver can see a pedestrian at any point in the crosswalk within the traveled way.

There is no minimum pedestrian volume for a school crossing.

It is recommended that a trained crossing guard be present at the times when there is crossing activity by students.

When a proposed crosswalk is associated with a new development, a change in land use, or new pedestrian facilities, an engineering study may be used to predict whether these criteria will be met once the development or facility has been constructed.

3.1.2 No parking zone:

Parking spaces should not be marked within 20 feet of a marked crosswalk, as measured by the gap between the parking space and the closest crosswalk marking. If a bulbout (see Figure 14 in section 5.3.6) is used, the gap may be reduced to 10 feet. Parents should be discouraged from using the area adjacent to the crosswalk for pickups and dropoffs.

3.1.3 School Crossing Signs:

1. The School Advance Crossing Assembly consists of the School symbol sign (S1-1) and a supplemental plaque with the legend "AHEAD" (W16-9P) or "XXX FEET" (W16-2 or W16-2a) to provide advance notice to road users of crossing activity.
 - a. The School Advance Crossing assembly shall be installed for school crosswalks along an established school route outside of a school zone, at least 125 feet in advance of the crosswalk.
 - b. The School Advance Crossing Assembly may be omitted within a school zone that is marked with School Advance warning signs (S1-1 school symbol signs with S4-3P "School" plaques.)
2. The School Crossing Assembly consists of the School symbol sign (S1-1) with a diagonal downward ARROW (W16-7P) below it.

- a. The School Crossing Assembly shall be installed at each end of the crosswalk location. At either end, the sign should be placed in advance of the crosswalk from the perspective of the driver in the adjacent travel lane, facing the driver.
 - b. The School Crossing Assembly shall not be used at marked crosswalks other than those within school zones or those on established school routes.
 - c. The School Crossing Assembly shall not be installed at intersection approaches controlled by a stop sign or a traffic signal.
3. The MUTCD requires that all School Warning Signs and supplemental plaques shall have a fluorescent yellow-green background with a black legend and border.

3.2 Non-School Crossings:

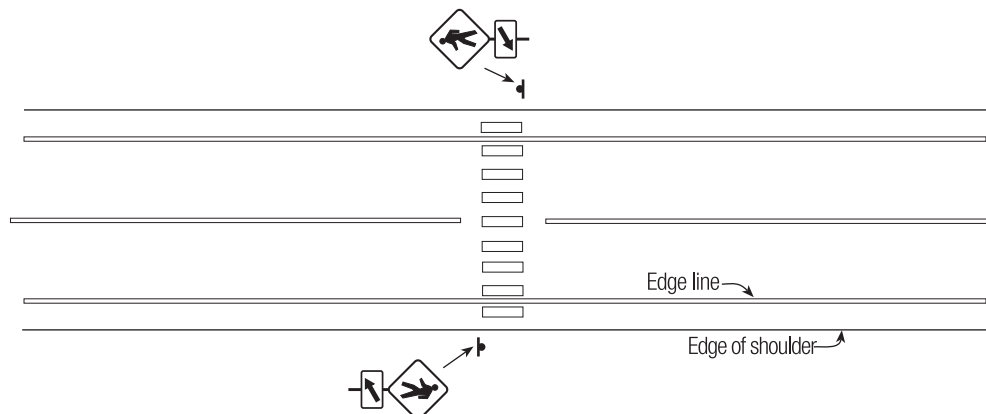

Figure 6: Mid-Block Crossing

Mid-block crossings may be used to facilitate pedestrian access and to concentrate pedestrian crossing activity in a safe location.

3.2.1 Criteria for installation:

All of the following criteria should be met prior to installing a crosswalk (unless supported by other factors using engineering judgment:)

1. The speed limit is 40 mph or less;

2. There are 20 or more pedestrians using the crossing per hour during the highest pedestrian volume hour (elementary school age and elderly pedestrians count as 2 each) ;
3. The AADT (annual average daily traffic) for the roadway (both directions combined) exceeds 3000 vehicles per day;
4. There is a sidewalk or adequate shoulder for use by pedestrians. The determination of adequate shoulder should be based upon an assessment of traffic volumes, adjacent land use patterns and other site specific conditions. The shoulder shall be a minimum of three feet wide, and a maximum of six feet wide (in order to minimize potential conflicts with parking activities.) Mid-block crossings may also be considered where there is a pedestrian destination, such as a recreation field, where a low potential for vehicle/pedestrian conflicts exists on both sides of the roadway;
5. There is not another crosswalk across the same roadway within 200 feet;
6. A determination has been made that the pedestrian shall have the right of way over the vehicular traffic;
7. There is adequate sight distance (equal to or exceeding the stopping sight distance for the posted speed) is available in both directions. At a minimum, a driver must be able to see either the crosswalk or the pedestrian warning sign. It is recommended that sight distance be measured from the driver's perspective to the outer edges of the traveled lanes, to ensure that an approaching driver can see a pedestrian at any point on the crosswalk within the traveled way.

In some situations where the traffic volume and/or pedestrian volume thresholds are not met (e.g., low-speed, two-lane roads in village centers), it may be determined that pedestrian safety would be enhanced by installing a marked crosswalk. Installing a marked crosswalk may help consolidate multiple crossing points or direct pedestrians to cross at a location that is more advantageous because of better sight distance, better lighting at night, or other factors. Engineering judgment should be used to locate the crosswalk if those conditions exist. However, in no case will an exception be made for installing a marked crosswalk on roads with a posted speed in excess of 40 MPH. Only one such crosswalk should be considered per village center.

When a proposed crosswalk is associated with a new development, change in land use, or new pedestrian facilities, an engineering study may be used to predict whether these criteria will be met once the development or facility has been constructed.

Crosswalks should not be marked on 3 or 4 lane roadways with AADT greater than 9,000 vehicles per day unless other crosswalk enhancements, such as pedestrian refuge islands, advanced yield lines, or rectangular rapid flashing beacons are included.

An engineering study should conclude that pedestrian safety will be enhanced by marking the crosswalk. See section 5.3 for more information about crosswalk enhancements.

3.2.2 *No parking zone:*

Parking spaces should not be marked within 20 feet of a marked crosswalk, as measured by the gap between the parking space and the closest crosswalk marking.

3.2.3 *Pedestrian Warning Signs:*

Pedestrian warning signs (W11-2 with downward arrow plaque W16-7P) shall be installed at each end of the crosswalk location. At either end, the sign should be placed in advance of the crosswalk from the perspective of the driver in the adjacent travel lane, facing the driver.

Advance pedestrian warning signs (W11-2) with supplemental plaques with the legend "AHEAD" (W16-9P) or "XXX FEET" (W16-2P or W16-2aP) may be installed in advance of the crosswalk in order to give drivers additional advance notice of the crosswalk. Advance warning signs are not typically used in urban areas where pedestrian activity is an expected feature of the driving environment.

3.2.4 *Sign Color*

All pedestrian warning signs and supplemental plaques shall have a fluorescent yellow-green background with a black legend and border.

3.3 **Crosswalk Stopping Sight Distance Chart:**

The following stopping sight distances for each posted speed are referenced from MUTCD Table 6C-2.

Posted Speed (mph)	Required Sight Distance (feet) *
25	155
30	200
35	250
40	305

* downgrades require longer stopping distances

Figure 7: Stopping Sight Distances

4.0 Unmarked Crossings

When the criteria for a marked crosswalk are not met, pedestrian warning signs may be installed to alert road users to locations where unexpected entries into the roadway by pedestrians might occur. There does not have to be a specific volume of pedestrians, merely crossing activity. These signs do not give the pedestrian the right of way over vehicular traffic, but serve to warn vehicle drivers that pedestrian activity may take place over a given area.

Passing zones should not be marked within 500 feet of the crossing area.

4.1 Unmarked Crossings

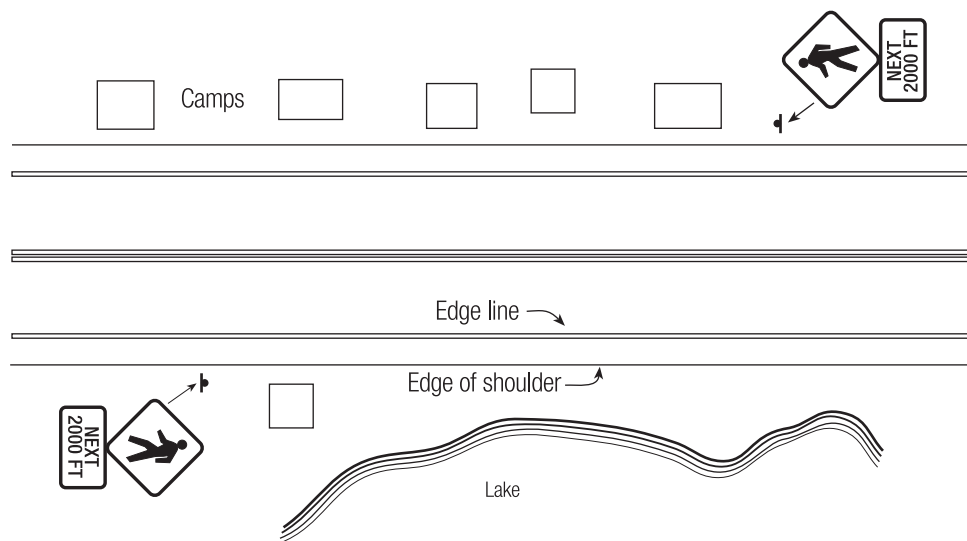

Figure 8: Unmarked Crossings

4.1.1 Pedestrian Warning Signs:

A pedestrian warning sign (W11-2) and a supplemental distance plaque “NEXT XXX FEET” (W16-4) should be installed at either end of the crossing area. The distance indicated should not exceed one mile. The minimum distance shall not be less than 100 feet.

4.1.2 Other features:

Curb ramps and detectable warning surfaces may be used to facilitate pedestrian accessibility at unmarked crossings if there is a particular point where pedestrians are likely to cross and sidewalks are present.

5.0 Design of Marked Crosswalks

5.1 Pavement Markings:

Crosswalk markings must conform to the MUTCD. It is also recommended that a municipality select just one of the marking patterns below for exclusive use within its jurisdiction. VTrans has adopted the block pattern with 2 ft wide blocks and 2 ft gaps as its standard crosswalk marking pattern due to greater visibility and reduced wear due to traffic. Crosswalks should be marked as close to perpendicular to traffic as possible.

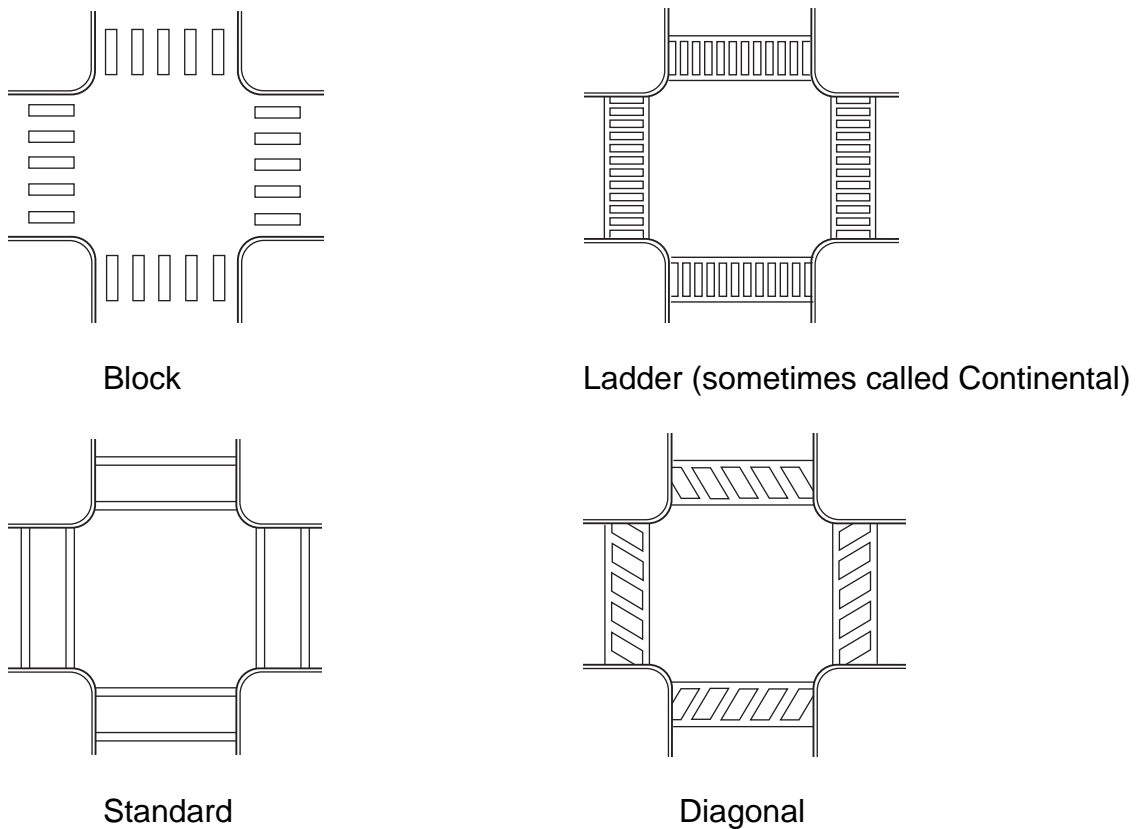

Figure 9: Allowable crosswalk marking patterns

5.2 Other Considerations:

5.2.1 ADA Compliance:

Where crosswalks provide access to sidewalks, curb ramps that meet the U.S. Access Board Public Rights of Way Accessibility Guidelines (PROWAG) must be provided at both ends of the crosswalk. Detectable warning surfaces are required at curb ramps. (See VTrans Standard Drawings C-3A and C-3B for curb ramp construction details.) If a crosswalk leads to a paved shoulder, it should meet PROWAG to the maximum extent feasible.

5.2.2 Shared-Use Paths:

Where shared-use paths cross roadways, crosswalks may be marked as for mid-block crossings and shall follow the guidance in Section 3.1 if part of a School route or 3.2 for other situations. Cyclists must dismount and cross the roadway as pedestrians to be afforded the same legal status as pedestrians.

5.2.3 Colored and Textured pavement:

In village and downtown centers, colored and textured pavement may be used to enhance the aesthetics of crosswalks. These options have not been proven to substantially improve crosswalk safety or visibility to the driver. Additionally, textured surfaces are not preferred by individuals who use wheelchairs as the surface causes uncomfortable vibrations.

The most common treatment is a terra-cotta colored, brick pattern that is stamped into newly laid asphalt. In accordance with the MUTCD, white, yellow, blue, red, purple and green shall not be used as infill colors for crosswalks since they are colors reserved for other traffic control purposes. No color used in a crosswalk may have retroreflective properties since that is a property reserved for traffic control devices.

Transverse white crosswalk markings must be used in addition to the colored or textured pavement in order to legally establish the crosswalk. Placing a colored and/or patterned area without the use of white crosswalk markings is not permitted by the MUTCD.

5.2.4 Use of Fluorescent Yellow-Green Signs:

It is VTrans practice to use fluorescent yellow-green for all pedestrian warning signs, and all school warning signs, but to use standard or fluorescent yellow for bicycle warning signs.

5.3 Enhancements to marked crosswalks at uncontrolled locations

In some cases, standard crosswalk signs and markings are not sufficient to provide an adequate level of safety at a marked crosswalk. In fact, using standard crosswalk signs and markings alone on roads with more than two lanes or with an AADT greater than 9000 may actually decrease the safety of pedestrians using the crossing location (*Zegeer, 2005, Safety Effects of Marked vs. Unmarked Crosswalks at Uncontrolled Locations*). If proposing a crosswalk with these conditions, one or more of the following crosswalk enhancements should be included. Each of the following treatments is discussed in more detail following this summary.

- In-street pedestrian sign – This is a stand-alone sign mounted on a base whose design allows the sign to bend if struck by a vehicle.
- Pedestrian refuge island – The island provides pedestrians with a facility on which they can wait, out of the flow of traffic, to cross portions of a road one at a time. They are most commonly used on multi-lane sections where there is more than one lane of traffic in a given direction.
- Advanced Yield Line – The advanced yield line is used on multi-lane sections so that vehicles must yield well in advance of a crosswalk, helping to avoid the so-called “multiple threat” scenario where a car in one lane yields, but traffic in the next lane over does not.
- Rectangular Rapid Flashing Beacon (RRFB) – The RRFB is a pedestrian activated flashing light mounted beneath the pedestrian warning sign to alert the driver of the pedestrian’s presence.
- Pedestrian Hybrid Beacon (PHB) – The PHB is a traffic control signal that remains dark until activated by a pedestrian. Traffic is then stopped while the pedestrian crosses the road.

Other enhancements that can be combined with any of the treatments above include:

- Installation of bulbouts at either mid-block or intersection crosswalks,
- Increasing sign visibility by use of reflective strips on the sign posts, using larger signs, or gateposting the signs (install back to back signs on both sides of the road.)
- Installation of street lights on the approach to crosswalks when there is nighttime use of the crosswalk

Use of crosswalk enhancements are generally based on three criteria: traffic volume, posted speed and lane configurations. The tables in Figures 10 and 11 indicate when marked crosswalks alone are appropriate or when use of enhancements should be considered. The tables also indicate which of the crosswalk enhancements should be considered for a given set of conditions. The tables are not meant to be proscriptive, but rather provide guidance on enhancements that could be used.

Figure 10: Appropriateness of Marked Crosswalks

Roadway Type	3000 ≤ AADT ≤ 9,000			AADT >9,000 and ≤ 12,000			AADT > 12,000		
	≤ 30 MPH	35 MPH	40 MPH	≤ 30 MPH	35 MPH	40 MPH	≤ 30 MPH	35 MPH	40 MPH
2 Lanes									
3 Lanes									
4 or more Lanes <u>with</u> Raised Median									
4 or more Lanes <u>without</u> Raised Median									

	Marked Crosswalk alone may be appropriate
	Additional crosswalk enhancements should be included
	Additional crosswalk enhancements must be included, a marked crosswalk alone is not appropriate

Figure 11: Crosswalk Enhancement Options to Consider

Roadway Type	3000 ≤ AADT ≤ 9,000			AADT >9,000 and ≤ 12,000			AADT > 12,000		
	≤ 30 MPH	35 MPH	40 MPH	≤ 30 MPH	35 MPH	40 MPH	≤ 30 MPH	35 MPH	40 MPH
2 Lanes	In-street sign	In-street sign	In-street sign, RRFB	In-street sign, RRFB	In-street sign, RRFB	In-street sign, RRFB	In-street sign, RRFB	In-street sign, RRFB	In-street sign, RRFB
3 Lanes	Ped Refuge	Ped Refuge	Ped Refuge, AYL, RRFB	Ped Refuge, AYL, RRFB	Ped Refuge, AYL, RRFB	Ped Refuge, AYL, RRFB	Ped Refuge, AYL, RRFB	Ped Refuge, AYL, RRFB	Ped Refuge, AYL, RRFB, PHB
4 or more Lanes <u>with</u> Raised Median*	AYL	AYL	AYL, RRFB	AYL, RRFB	AYL, RRFB	AYL, RRFB, PHB	AYL, RRFB	AYL, RRFB	AYL, RRFB, PHB
4 or more lanes <u>without</u> raised median	Ped Refuge, AYL	Ped Refuge, AYL	Ped Refuge, AYL, RRFB, PHB	Ped Refuge, AYL, RRFB	Ped Refuge, AYL, RRFB	Ped Refuge, AYL, PHB	AYL, RRFB	Ped Refuge, RRFB, AYL, PHB	Ped Refuge, AYL, PHB

*In this configuration, the Raised Median serves as the pedestrian refuge. Some modifications to a raised median, such as ramps and the provision of detectable warning surfaces and signs, may be required.

In-street sign = In-street pedestrian crossing sign

Ped Refuge = Pedestrian Refuge Island

AYL = Advanced Yield Line and required regulatory signs

RRFB = Rectangular Rapid Flashing Beacons

PHB = Pedestrian Hybrid Beacon

5.3.1 In-street Pedestrian Sign

The in-street pedestrian sign is a basic enhancement that may be added to crosswalks to enhance their visibility. MUTCD Reference – Section 2B.12
The use of in-street pedestrian signs shall be in accordance with the items listed below:

1. The in-street sign may only be used on a state maintained highway after completing and receiving a permit from the VT Agency of Transportation through a request to the Traffic Operations section.
2. The sign shall be placed in the roadway at the crosswalk location, either on the centerline, on the lane line, or on the median island if one is present. They shall not be post-mounted on either side of the roadway. The sign shall not be placed in the crosswalk itself.
3. The in-street sign shall not be used at signalized locations or at locations without a marked crosswalk.
4. The sign support shall be designed to bend over and bounce back to its normal position if struck by a vehicle.
5. Use of reflectorized cones or barrels in place of or in addition to the in-street sign is not permitted.
6. The in-street sign background sheeting color shall match the color of the crosswalk warning signs at the crosswalk where it is to be used.
7. At no time shall any object be attached to the in-street sign.

When the in-street crossing sign is not being used (i.e. either seasonally or at night, during inclement weather or when no activity occurs) it shall be removed from the roadway and stored out of view of the traveling public.

The municipality in which the sign is located is responsible for all injuries or damages received or sustained by any person, persons or property, including all costs or expenses to defend against such suits, actions or claims related to any incident involving the sign. The sign design shall be as shown below.

*In-street pedestrian crossing sign with
Fluorescent yellow-green sheeting*



R1-6

5.3.2 Pedestrian Refuge Island

Medians and center refuge islands at intersections and midblock locations provide a waiting area for pedestrians, and eliminate the need for pedestrians to cross both directions of traffic at once. They help define the pedestrian walking space and, if large enough, provide protection and refuge from motor vehicles. This is particularly important on wide, higher volume, higher-speed roadways. Pedestrians trying to cross an undivided, multilane street may experience delays many times longer than the delay incurred crossing a street with a median. Streets with raised medians, in both central business districts and suburban areas, have lower pedestrian crash rates (between 50% and 75% crash reduction) compared to streets with a painted two-way left-turn lane or undivided streets.

Medians and refuge islands are a benefit to drivers when located at midblock crossings, because they help to better identify the upcoming crossing point. They also provide a location for a pedestrian crossing sign in the middle of the street, providing another opportunity to warn drivers of the crossing.

Refuge islands are typically shorter than medians, but either can be used at intersections. Medians and center refuge islands provide the benefit of turning a two-way street into two one-way streets from the perspective of the pedestrian. The preferred design of medians and refuge islands follows the Institute of Transportation Engineer's Design and Safety of Pedestrian Facilities guidelines.

Medians and refuge islands have a preferred width of 8 to 10 feet and a minimum width of 6 feet to hold bicyclists, people with strollers, and wheelchairs propelled by attendants, outside the travel lanes. The 6 foot width is also the minimum needed to correctly install detectable warning surfaces in the median. In some cases, smaller width medians and refuge islands may be acceptable where there is a severely constrained right-of-way.

In order to obtain appropriate median width, travel lanes can be narrowed to minimum widths as outlined in the VT State Standards. This can have the added effect of slowing motor vehicle speeds at the crossing location. On the state highway system, an absolute minimum curb to curb (or other obstruction such as parked cars) distance of 14 feet must be maintained to accommodate snow removal.

An important consideration for pedestrian refuge islands is maintenance of openings for use by pedestrians in the winter. It is critical that a public agency take responsibility for removing snow from the refuge island so that it can be used year-round. If this is not addressed, pedestrians may stand/wait in unsafe areas and people with disabilities will be even more vulnerable as they seek a path outside of the refuge area.

For wider refuges, it is preferred to angle the opening that pedestrians will use. The purpose of this is to force pedestrians to face oncoming traffic as they traverse the refuge, ensuring that they assess whether there is a gap before crossing.



Photo of Pedestrian Refuge Island (note that detectable warning surface should be provided on either edge of the opening in the island).

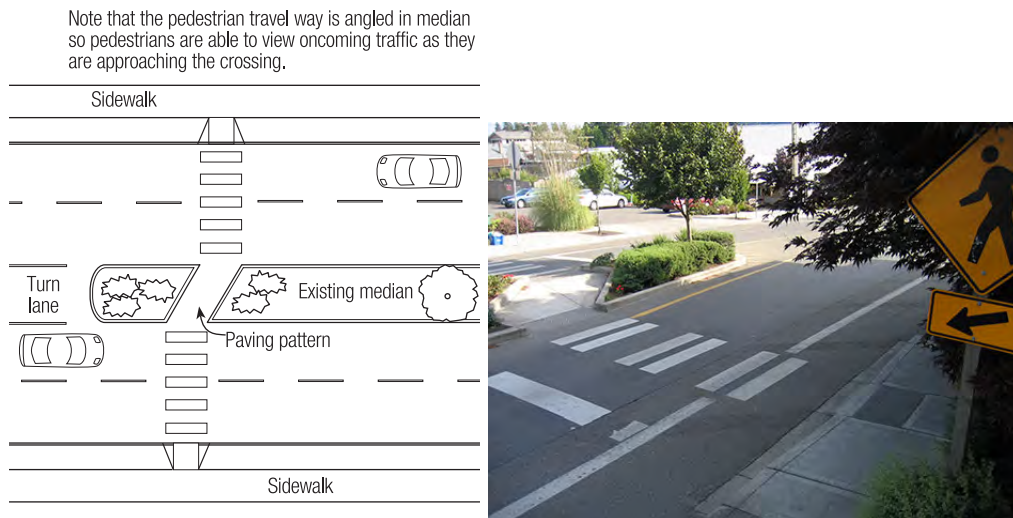

Illustration and photo of angled opening in pedestrian refuge to encourage pedestrians to view oncoming traffic.

Figure 12: Pedestrian Refuge Island

5.3.3 Advanced Yield Line

On multi-lane crossings, the predominant threat to pedestrians is what is known as the multiple-threat crash. In this crash type, a vehicle stops in the lane closest to the curb where the pedestrian is starting to cross. The pedestrian enters the crosswalk and the vehicle in the next lane over does not see the pedestrian and continues past the stopped vehicle, striking the crossing pedestrian (see illustration below.) One of the simplest design solutions to address this crash type is an advanced yield line. Advanced Yield Lines consist of signs and pavement markings and are discussed in the MUTCD (Section 2B.11 for signs, 3B.16 for markings).

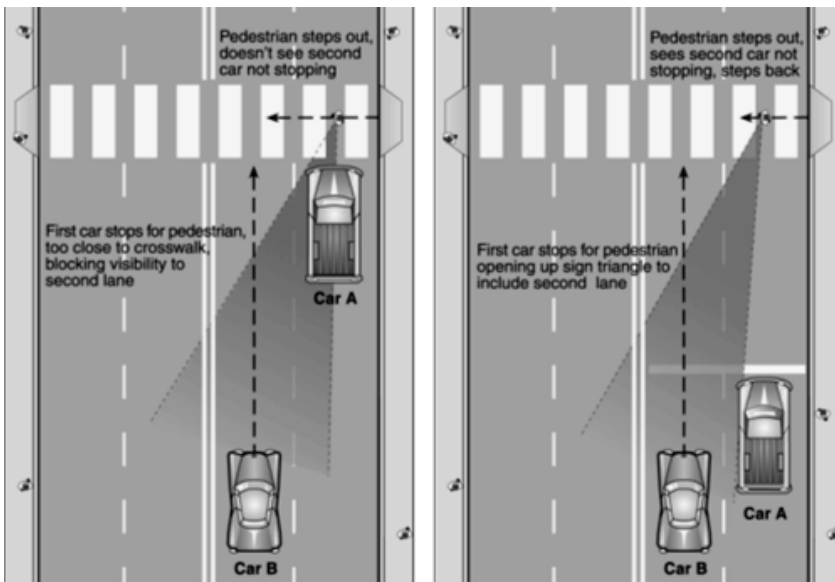

Illustration of Multiple threat scenario (note that in this example, an advanced stop bar is shown. In VT, the law is “Yield to pedestrians”, so it would be an advanced Yield line – see below)

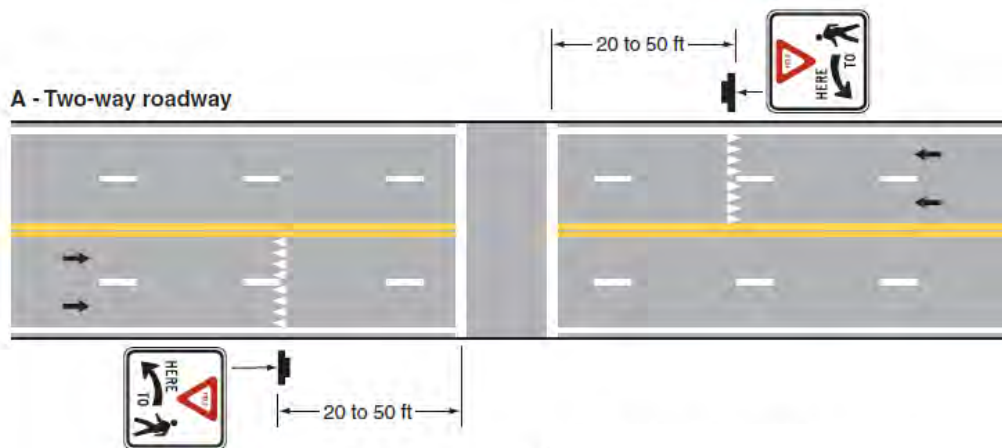

Figure 13 – Advanced Yield Line

The advanced yield line and associated signs indicate to motorists that they must yield at some distance in advance of the crosswalk. This allows for a better line of sight from motorists to crossing pedestrians and keeps cars stopping in the curb-side lane from blocking pedestrian's line of sight to other cars.

In addition to the “sharks tooth” yield line markings, an advanced yield line must include the appropriate regulatory signs. The yield line and signs shall be located 20 – 50 feet in advance of the nearest crosswalk line.



R1-5 Regulatory sign to accompany Advanced Yield Line

5.3.4 RRFBs (*Rectangular Rapid Flashing Beacon*)

Rectangular Rapid Flashing Beacons (RRFB) are meant to be used to provide supplemental emphasis to the W11-2 Pedestrian sign. The FHWA issued interim approval for this traffic control device in 2008. RRFBs consist of a pair of pedestrian activated flashing lights installed with a crosswalk warning sign. They should be used in situations where increased emphasis is needed to alert drivers to pedestrian crossings (see Figures 10 and 11). Additional background information on the effectiveness of RRFBs may be found in the FHWA memo found in the appendix.



Photo of RRFB installation at a marked crosswalk.

The following is a list of factors that should be addressed where RRFBs are being considered. These factors should not be interpreted as warrants for RRFBs nor pass/fail criteria for the installation of RRFBs. However, these conditions have been identified as ones to be considered using engineering judgment when proposing RRFBs at crosswalks on State Highways. The overuse of RRFBs in the roadway environment could decrease not only the effectiveness of RRFBs but those crossings without RRFBs. RRFBs should be limited to locations with the most critical safety concerns.

1. RRFBs typically work best at locations where special emphasis is required, such as crossings with a high percentage of vulnerable pedestrians (predominately young, elderly or disabled), or a history of pedestrian crashes.

See Figure 11 for volume, speed and lane configuration conditions that indicate where RRFBs should be considered.

2. Proven pedestrian safety measures such as median refuge islands and/or curb bulb-outs may be used in conjunction with the installation of RRFBs.
3. RRFBs shall only be used at uncontrolled crosswalks (i.e. not controlled by STOP, YIELD or signals).
4. RRFB's should be considered where the crosswalk has significant nighttime pedestrian activity.
5. Either automatic (passive detection) or push-button activation is allowed. If push-button activated the proper signing shall be attached next to the push-button, with the legend "PUSH BUTTON TO TURN ON WARNING LIGHTS" R10-25 sign in the 2009 MUTCD. If push-button activated, the push button shall include accessible features such as an audible locator tone and it must be accessible from the sidewalk.
6. In most cases, RRFBs will be owned and maintained by the municipality in which they are located. Either a finance and maintenance agreement or conditions within a Section 1111 permit will assign this responsibility for RRFBs installed on State highways.

Notwithstanding these factors, any RRFB installation shall follow all of the guidance outlined in the July 16, 2008 FHWA Memo regarding RRFBs (see Appendix A.)

5.3.5 Pedestrian Hybrid Beacon

The pedestrian hybrid beacon (PHB) should be used where it has been determined that it is necessary to legally stop traffic to allow pedestrians to cross. Until a PHB is activated by a pedestrian wishing to cross, it remains dark. Once activated, it goes through a series of indications that first warn, then stop, oncoming traffic to allow pedestrians to cross the road. The MUTCD has specific criteria for traffic and pedestrian volumes that must be met before a PHB should be considered and also contains detailed design guidance on the configuration and operations of a PHB (Chapter 4F.) Additionally, see Figure 11 for the conditions that must be present before a PHB should be considered. The PHB will have an impact on roadway capacity and congestion and should only be considered if all other measures to ensure safe crossing by pedestrians have been exhausted.



Typical installation of Pedestrian Hybrid Beacon

5.3.6 Bulbouts

Bulbouts may be used with any of the enhancements above, if there is adequate space in the roadway to use them. Bulbouts (also known as curb extensions, neckdowns, flares, or chokers) reduce the pedestrian crossing distance and improve the visibility of pedestrians to motorists and vice versa. Consider installing curb extensions at any intersection where on-street parking is allowed. The crossing distance savings are greatest when used on streets with diagonal parking. Where bike lanes or paved shoulders are present, bulbouts should be designed to maintain access for bicyclists.

Bulbouts work particularly well on streets where there is limited turning traffic by buses and large vehicles, or streets that accommodate one-way traffic, and on minor streets in residential areas. bulbouts typically have the effect of reducing the curb radius.

At signalized crossings, bulbouts reduce pedestrian crossing distance, which improves signal timing if the pedestrian phase controls the signal. The time saved is substantial when two corners can be treated with bulbouts.

Bulbouts at intersections or mid-block offer the following positive features:

- Reduce the distance that pedestrians must cross, lessening the time that they are exposed to traffic.
- Improve the ability of motorists and pedestrians to see one another.
- Increased ability to use paired curb ramps at intersections.
- Provide space for street furniture or utility infrastructure, if it can be located without interfering with sight lines.
- Provide a traffic calming effect along the roadway.

One consideration for bulbouts is that they do result in slightly more complex snow removal.

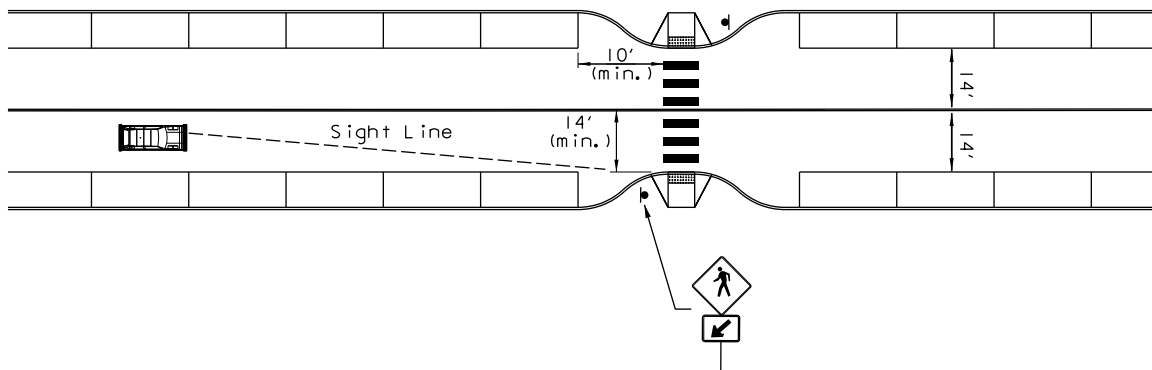

Figure 14: Mid-block Bulbout Example

6.0 Vermont Law:

The following are excerpts from the Vermont Statutes, 2013 Edition, as they refer to pedestrian crossings:

Title 23 Section 4 Definitions (7) "Crosswalks": Defines crosswalks as:

(A) That part of a roadway at an intersection included within the connections of the lateral lines of the sidewalks on opposite sides of the highway measured from the curbs, or, in the absence of curbs, from the edges of the traversable roadway.

(B) Any portion of a roadway at an intersection or elsewhere distinctly indicated for pedestrian crossing by lines or other markings on the surface;"

Title 23 Section 1025 Adopts the MUTCD as Vermont's "standards for all signs, signals and markings within the state."

Title 19 Section 905b Crosswalks states:

All crosswalk markings shall be of uniform color, dimension and location and be in conformance with the United States Department of Transportation Federal Highway Administration's Manual on Uniform Traffic Control Devices.

Title 23 Section 1051 Pedestrians' right of way in crosswalks states:

(a) If traffic-control signals are not in operation, the driver of a vehicle shall yield the right-of-way, slowing down or stopping if necessary, to a pedestrian crossing the roadway within the crosswalk.

(b) No pedestrian may suddenly leave a curb or other place of safety and walk or run into the path of a vehicle which is so close that it is impossible for a driver to yield.

(c) If any vehicle is stopped at a marked crosswalk or at any unmarked crosswalk at an intersection to permit a pedestrian to cross the roadway, the driver of any other vehicle approaching from the rear may not overtake and pass the stopped vehicle.

Title 23 Section 1052 Crossing except at crosswalks states:

(a) Every pedestrian crossing a roadway at any point other than within a marked crosswalk shall yield the right-of-way to all vehicles upon the roadway.

(b) Every pedestrian crossing a roadway at a point where a pedestrian tunnel or overhead pedestrian crossing has been provided shall yield the right of way to all vehicles upon the roadway.

(c) Between adjacent intersections at which traffic-control signals are in operation pedestrians may not cross at any place except in a marked crosswalk.

(d) No pedestrian may cross a roadway intersection diagonally unless authorized by official traffic-control devices or an enforcement officer. When authorized to cross diagonally, pedestrians may cross only in accordance with the official traffic-control devices or signal of an enforcement officer.

Title 23 Section 1054 Pedestrians to use right half of crosswalks states:

Pedestrians may move, whenever practicable, upon the right half of crosswalks only.

Title 23 Section 1057 Duty toward Blind Persons sets forth the requirement for drivers to stop for persons guided by a guide dog or displaying a white or white tipped with red cane and requires that only blind persons may use those.

Title 23 Section 1058 Duties of pedestrians states:

All pedestrians shall obey the instructions of all traffic control devices which are applicable to them, and all instructions of enforcement officers relating to control of traffic.

Title 23 Section 1104(a)(2)(C) Stopping Prohibited states:

Except when necessary to avoid conflict with other traffic, or in compliance with law or the directions of an enforcement officer or official traffic-control device, no person may stand or park a vehicle, whether occupied or not, except momentarily to pick up or discharge a passenger, within 20 feet of a crosswalk at an intersection.

7.0 MUTCD Support and Guidance:

MUTCD Section 3B.18 states in part:

“Crosswalk markings provide guidance for pedestrians who are crossing roadways by defining and delineating paths on approaches to and within signalized intersections, and on approaches to other intersections where traffic stops.

In conjunction with signs and other measures, crosswalk markings help to alert road users of a designated pedestrian crossing point across roadways at locations that are not controlled by traffic control signals or STOP or YIELD signs.

At non-intersection locations, crosswalk markings legally establish the crosswalk.

At locations controlled by traffic control signals or on approaches controlled by STOP or YIELD signs, crosswalk lines should be installed where engineering judgment indicates they are needed to direct pedestrians to the proper crossing path(s).

Crosswalk lines should not be used indiscriminately. An engineering study should be performed before they are installed at locations away from a traffic signal or an approach controlled by a STOP or YIELD sign. The engineering study should consider the number of lanes, the presence of a median, the distance from adjacent signalized intersections, the pedestrian volumes and delays, the average daily traffic (ADT), the posted or statutory speed limit or 85th-percentile speed, the geometry of the location, the possible consolidation of multiple crossing points, the availability of street lighting, and other appropriate factors.

Because non-intersection pedestrian crossings are generally unexpected by the road user, warning signs ... should be installed for all marked crosswalks at non-intersection locations and adequate visibility should be provided by parking prohibitions.

Detectable warning surfaces mark boundaries between pedestrian and vehicular ways where there is no raised curb. Detectable warning surfaces are required by 49 CFR, Part 37 and by the Americans with Disabilities Act (ADA) where curb ramps are constructed at the junction of sidewalks and the roadway, for marked and unmarked crosswalks. Detectable warning surfaces contrast visually with adjacent walking surfaces, either light-on-dark, or dark-on-light. The “Americans with Disabilities Act Accessibility Guidelines for Buildings and Facilities (ADAAG)” contains specifications for design and placement of detectable warning surfaces.

MUTCD Section 3A.02 contains the standard for pavement marking retroreflectivity:

“Markings that must be visible at night shall be retroreflective unless ambient illumination assures that the markings are adequately visible.”

MUTCD Section 3B.18 provides standards and guidance for the design of crosswalks. Those portions specifying the design of the pavement markings are excerpted as follows:

Standard:

When crosswalk lines are used, they shall consist of solid white lines that mark the crosswalk. They shall be not less than 6 inches nor greater than 24 inches in width.

Guidance:

If transverse lines are used to mark a crosswalk, the gap between the lines should not be less than 6 feet. If diagonal or longitudinal lines are used without transverse lines to mark a crosswalk, the crosswalk should be not less than 6 feet wide. *[Note: VTrans Standard practice is to mark crosswalks a minimum width of 8 feet.]*

Crosswalk lines, if used ... should extend across the full width of pavement or to the edge of the intersecting crosswalk to discourage diagonal walking between crosswalks.

Option:

For added visibility, the area of the crosswalk may be marked with diagonal lines at a 45-degree angle to the line of the crosswalk or with white longitudinal lines parallel to traffic flow.

When diagonal or longitudinal lines are used to mark a crosswalk, the transverse crosswalk lines may be omitted. This type of marking may be used at locations where substantial numbers of pedestrians cross without any other traffic control device, at locations where physical conditions are such that added visibility of the crosswalk is desired, or at places where a pedestrian crosswalk might not be expected.

Guidance:

If used, the diagonal or longitudinal lines should be 12 to 24 inches wide and separated by gaps of 12 to 60 inches. The design of the lines and

gaps should avoid the wheel paths if possible, and the gap between the lines should not exceed 2.5 times the width of the diagonal or longitudinal lines.

Crosswalk markings should be located so that the curb ramps are within the extension of the crosswalk markings.

MUTCD Section 3B.16 provides standards and guidance for the placement of Stop and Yield lines. The guidance as it applies to crosswalks is as follows:

Guidance:

If used, stop and yield lines should be placed a minimum of 4 feet in advance of the nearest crosswalk line at controlled intersections, except for yield lines at roundabout intersections as provided for in section 3C.04 and at midblock crosswalks.

If yield or stop lines are used at a crosswalk that crosses an uncontrolled multi-lane approach, the yield lines or stop lines should be placed 20 to 50 feet in advance of the nearest crosswalk line, and parking should be prohibited in the area between the yield or stop line and the crosswalk.

MUTCD Section 3C.05 provides guidance for the placement of crosswalk markings at roundabouts:

Standard:

Pedestrian crosswalks shall not be marked to or from the central island of roundabouts.

Guidance:

If pedestrian facilities are provided, crosswalks should be marked across roundabout entrances and exits to indicate where pedestrians are intended to cross.

Crosswalks should be a minimum of 20 feet from the edge of the circulatory roadway.

MUTCD Sections 2C.49 and 50 provide standard and guidance for crossing signs and allow fluorescent yellow-green to be used for pedestrian and bicycle related warning signs and associated plaques.

MUTCD Section 7B.07 requires that all school related warning signs and associated plaques be fluorescent yellow-green.

MUTCD Section 2B.12 provides standards and guidance for the use of in-street pedestrian crossing signs.

Option:

The In-Street Pedestrian Crossing (R1-6 or R1-6a) sign...may be used to remind road users of laws regarding right of way at an unsignalized pedestrian crosswalk. The legend STATE LAW may be shown at the top of the sign if applicable. *[Note: Vermont State Law specifies that drivers must YIELD TO pedestrians in crosswalks.]*

Guidance:

If an island is available, the In-Street Pedestrian Crossing Sign, if used, should be placed on the island.

Standard:

The In-Street Pedestrian Crossing sign shall not be used at signalized intersections.

The STOP FOR legend shall only be used in States where the state law specifically requires that a driver must stop for a pedestrian in a crosswalk.

If used, the In-Street Pedestrian Crossing sign shall have a black legend (except for the red STOP or YIELD sign symbols) and border on a white background, surrounded by an outer yellow or fluorescent yellow-green background area. *[Note: It is VTrans practice to require that the background color of the In-Street Pedestrian Crossing sign match the color of the associated pedestrian crossing signs, which may be yellow, fluorescent yellow, or fluorescent yellow-green.]*

Unless the In-Street Pedestrian Crossing sign is placed on a physical island, the sign support shall be designed to bend over and then bounce back to its normal vertical position when struck by a vehicle.

Option:

The In-Street Pedestrian Crossing sign may be used seasonally to prevent damage in winter because of plowing operations, and may be removed at night if the pedestrian activity at night is minimal." *[Note: It is VTrans practice to require the removal of these signs during snow events and at night by the permit holder.]*

8.0 Resources and References

Manual on Uniform Traffic Control Devices (MUTCD)

Federal Highway Administration

<http://mutcd.fhwa.dot.gov/index.htm>

Motor Vehicle Laws of Vermont (Title 23)

<http://www.leg.state.vt.us/statutesMain.cfm>

Vermont Pedestrian and Bicycle Facility Planning and Design Manual

Vermont Agency of Transportation, 2002

<http://vtransengineering.vermont.gov/bureaus/mab/local-projects/bike-ped>

Public Rights of Way Accessibility Guidelines (PROWAG)

US Access Board

<http://www.access-board.gov/guidelines-and-standards/streets-sidewalks>

Safety Effects of Marked Vs. Unmarked Crosswalks at Uncontrolled Intersections, FHWA, September 2005

<http://www.fhwa.dot.gov/publications/research/safety/04100/>

Informational Report on Lighting Design for Midblock Crosswalks

FHWA, April 2008

<http://www.fhwa.dot.gov/publications/research/safety/08053/>

Appendix A – July 2008 FHWA Interim Approval of RRFBs



Memorandum

Sent via Electronic Mail

Subject: **INFORMATION:** MUTCD – Interim Approval for
Optional Use of Rectangular Rapid Flashing Beacons (IA-11)

Date: July 16, 2008

From: Anthony T. Furst /s/ *Anthony T. Furst*
Acting Associate Administrator
for Operations

Reply to
Attn. of: HOTO-1

To: Associate Administrators
Chief Counsel
Acting Chief Financial Officer
Directors of Field Services
Federal Lands Highway Division Engineers
Resource Center Director
Division Administrators

Purpose: The purpose of this memorandum is to issue an Interim Approval for the optional use of Rectangular Rapid Flashing Beacons (RRFB) as warning beacons under certain limited conditions. Interim Approval allows interim use, pending official rulemaking, of a new traffic control device, a revision to the application or manner of use of an existing traffic control device, or a provision not specifically described in the Manual on Uniform Traffic Control Devices (MUTCD).

Background: The Florida Department of Transportation, in conjunction with the city of St. Petersburg, has requested that the Federal Highway Administration (FHWA) issue an Interim Approval to allow the use of RRFBs as warning beacons to supplement standard pedestrian crossing and school crossing warning signs at crossings across uncontrolled approaches. The RRFB does not meet the current standards for flashing warning beacons as contained in the 2003 edition of the MUTCD, Chapter 4K which requires a warning beacon to be round in shape and either 8 or 12 inches in diameter, to flash at a rate of approximately once per second, and to be located no less than 12 inches outside the nearest edge of the warning sign it supplements. The RRFB uses rectangular-shaped high-intensity LED-based indications, flashes rapidly in a wig-wag "flickering" flash pattern, and is mounted immediately between the crossing sign and the sign's supplemental arrow plaque.

**MOVING THE
AMERICAN
ECONOMY**



Research on the RRFB: The city of St. Petersburg has completed experimentation with the RRFB at 18 pedestrian crosswalks across uncontrolled approaches and has submitted their final report. In addition to "before" data, the city collected "after" data at intervals for 1 year at all sites and for 2 years at the first 2 implemented sites. For the first 2 sites, the city collected data for overhead and ground-mounted pedestrian crossing signs supplemented with standard round yellow flashing beacons, for comparison purposes, before the RRFBs were installed. The data show very high rates of motorist "yield to pedestrians" compliance, mostly in the high 80s to close to 100 percent, in comparison to far lower rates (in the 15 to 20 percent range) for standard beacons. The very high yielding rates are sustained even after 2 years in operation, and no identifiable negative effects have been found. The RRFB's very high compliance rates are previously unheard of for any device other than a full traffic signal and a "HAWK" hybrid signal, both of which stop traffic with steady red signal indications. The St. Petersburg data also shows that drivers exhibit yielding behavior much further in advance of the crosswalk with RRFB than with standard round yellow flashing beacons. These data clearly document very successful and impressive positive experience with the RRFBs at crosswalks in that city.

In addition to the St. Petersburg locations, experimentation is underway at 3 sites in Miami-Dade County, FL, 4 sites in Largo, FL, and 2 sites in Las Cruces, NM, and RRFBs are being installed at 3 sites in northern Illinois. Additionally, the District of Columbia has installed RRFBs at one crosswalk and plans to request experimentation with RRFB at several sites. Data from locations other than St. Petersburg is limited but does show results very similar to those found in St. Petersburg. A study of 2 RRFB locations in Miami-Dade County, FL, reported in a TRB paper, found that evasive conflicts between drivers and pedestrians and the percentage of pedestrians trapped in the center of an undivided road because of a non-yielding driver in the second half of the roadway were both significantly reduced to negligible levels. Data so far from the one RRFB site in DC shows driver yielding compliance rates increased from 26 percent to 74 percent after 30 days in operation and advance yielding distances also increased comparable to the St. Petersburg results.

FHWA Evaluation of Results: The Office of Transportation Operations has reviewed the available data and considers the RRFB to be highly successful for the applications tested (uncontrolled crosswalks). The RRFB offers significant potential safety and cost benefits, because it achieves very high rates of compliance at a very low relative cost in comparison to other more restrictive devices that provide comparable results, such as full midblock signalization. The components of RRFB are not proprietary and can be assembled by any jurisdiction with off-the-shelf hardware. The FHWA believes that the RRFB has a low risk of safety or operational concerns. However, because proliferation of RRFBs in the roadway environment to the point that they become ubiquitous could decrease their effectiveness, use of RRFBs should be limited to locations with the most critical safety concerns, such as pedestrian and school crosswalks across uncontrolled approaches, as tested in the experimentation.

At a recent meeting of the National Committee on Uniform Traffic Control Devices, the Signals Technical Committee voted to endorse the future inclusion of the RRFB for uncontrolled crosswalks into the MUTCD and recommended that FHWA issue an Interim Approval for RRFB. The FHWA believes this indicates a consensus in the practitioner community in support of optional use of RRFB. This Interim Approval does not create a new mandate compelling installation of RRFB but will allow agencies to install this type of flashing beacon, pending official MUTCD rulemaking, to provide a degree of enhanced pedestrian safety at uncontrolled crosswalks that has been previously unattainable without costly and delay-producing full traffic signalization.

Conditions of Interim Approval: The FHWA will grant Interim Approval for the optional use of the RRFB as a warning beacon to supplement standard pedestrian crossing or school crossing signs at crosswalks across uncontrolled approaches to any jurisdiction that submits a written request to the Office of Transportation Operations. A State may request Interim Approval for all jurisdictions in that State. Jurisdictions using RRFB under this Interim Approval must agree to comply with the technical conditions detailed below, to maintain an inventory list of all locations where the devices are placed, and to comply with Item F at the bottom of Page 1A-6 of the 2003 MUTCD, Section 1A.10 which requires:

"An agreement to restore the site(s) of the Interim Approval to a condition that complies with the provisions in this Manual within 3 months following the issuance of a Final Rule on this traffic control device. This agreement must also provide that the agency sponsoring the Interim Approval will terminate use of the device or application installed under the Interim Approval at any time that it determines significant safety concerns are directly or indirectly attributable to the device or application. The FHWA's Office of Transportation Operations has the right to terminate the interim approval at any time if there is an indication of safety concerns."

1. General Conditions:

- a. An RRFB shall consist of two rapidly and alternately flashed rectangular yellow indications having LED-array based pulsing light sources, and shall be designed, located, and operated in accordance with the detailed requirements specified below.
- b. The use of RRFBs is optional. However, if an agency opts to use an RRFB under this Interim Approval, the following design and operational requirements shall apply, and shall take precedence over any conflicting provisions of the MUTCD for the approach on which RRFBs are used:

2. Allowable Uses:

- a. An RRFB shall only be installed to function as a Warning Beacon (see 2003 MUTCD Section 4K.03).
- b. An RRFB shall only be used to supplement a W11-2 (Pedestrian) or S1-1 (School) crossing warning sign with a diagonal downward arrow (W16-7p) plaque, located at or immediately adjacent to a marked crosswalk.
- c. An RRFB shall not be used for crosswalks across approaches controlled by YIELD signs, STOP signs, or traffic control signals. This prohibition is not applicable to a crosswalk across the approach to and/or egress from a roundabout.
- d. In the event sight distance approaching the crosswalk at which RRFBs are used is less than deemed necessary by the engineer, an additional RRFB may be installed on that approach in advance of the crosswalk, as a Warning Beacon to supplement a W11-2 (Pedestrian) or S1-1 (School) crossing warning sign with an AHEAD: (W16-9p) plaque. This additional RRFB shall be supplemental to and not a replacement for RRFBs at the crosswalk itself.

3. Sign/Beacon Assembly Locations:

- a. For any approach on which RRFBs are used, two W11-2 or S1-1 crossing warning signs (each with RRFB and W16-7p plaque) shall be installed at the crosswalk, one on the right-hand side of the roadway and one on the left-hand side of the roadway. On a divided highway, the left-hand side assembly should be installed on the median, if practical, rather than on the far left side of the highway.
- b. An RRFB shall not be installed independent of the crossing signs for the approach the RRFB faces. The RRFB shall be installed on the same support as the associated W11-2 (Pedestrian) or S1-1 (School) crossing warning sign and plaque.

4. Beacon Dimensions and Placement in Sign Assembly:

- a. Each RRFB shall consist of two rectangular-shaped yellow indications, each with an LED-array based light source. Each RRFB indication shall be a minimum of approximately 5 inches wide by approximately 2 inches high.
- b. The two RRFB indications shall be aligned horizontally, with the longer dimension horizontal and with a minimum space between the two indications of approximately seven inches (7 in), measured from inside edge of one indication to inside edge of the other indication.

c. The outside edges of the RRFB indications, including any housings, shall not project beyond the outside edges of the W11-2 or S1-1 sign.

d. As a specific exception to 2003 MUTCD Section 4K.01 guidance, the RRFB shall be located between the bottom of the crossing warning sign and the top of the supplemental downward diagonal arrow plaque (or, in the case of a supplemental advance sign, the AHEAD plaque), rather than 12 inches above or below the sign assembly. (See attached example photo.)

5. Beacon Flashing Requirements:

a. When activated, the two yellow indications in each RRFB shall flash in a rapidly alternating "wig-wag" flashing sequence (left light on, then right light on).

b. As a specific exception to 2003 MUTCD Section 4K.01 requirements for the flash rate of beacons, RRFBs shall use a much faster flash rate. Each of the two yellow indications of an RRFB shall have 70 to 80 periods of flashing per minute and shall have alternating but approximately equal periods of rapid pulsing light emissions and dark operation. During each of its 70 to 80 flashing periods per minute, one of the yellow indications shall emit two rapid pulses of light and the other yellow indication shall emit three rapid pulses of light.

c. The flash rate of each individual yellow indication, as applied over the full on-off sequence of a flashing period of the indication, shall not be between 5 and 30 flashes per second, to avoid frequencies that might cause seizures.

d. The light intensity of the yellow indications shall meet the minimum specifications of Society of Automotive Engineers (SAE) standard J595 (Directional Flashing Optical Warning Devices for Authorized Emergency, Maintenance, and Service Vehicles) dated January 2005.

6. Beacon Operation:

a. The RRFB shall be normally dark, shall initiate operation only upon pedestrian actuation, and shall cease operation at a predetermined time after the pedestrian actuation or, with passive detection, after the pedestrian clears the crosswalk.

b. All RRFBs associated with a given crosswalk (including those with an advance crossing sign, if used) shall, when activated, simultaneously commence operation of their alternating rapid flashing indications and shall cease operation simultaneously.

c. If pedestrian pushbuttons (rather than passive detection) are used to actuate the RRFBs, a pedestrian instruction sign with the legend PUSH BUTTON TO TURN ON WARNING LIGHTS should be mounted adjacent to or integral with each pedestrian pushbutton.

- d. The duration of a predetermined period of operation of the RRFBs following each actuation should be based on the MUTCD procedures for timing of pedestrian clearance times for pedestrian signals.
 - e. A small light directed at and visible to pedestrians in the crosswalk may be installed integral to the RRFB or push button to give confirmation that the RRFB is in operation.
7. Other:
- a. Except as otherwise provided above, all other provisions of the MUTCD applicable to Warning Beacons shall apply to RRFBs.

Any questions concerning this Interim Approval should be directed to Mr. Scott Wainwright at scott.wainwright@dot.gov or by telephone at 202-366-0857.



Example of RRFB with W11-2 sign and W16-7p plaque at crosswalk across uncontrolled approach. [Photo courtesy of City of St. Petersburg, Florida]

FHWA:HOTO-1:SWainwright:ds:60857:7-2-08

cc: HOTO-1 HOTO-1(HKalla/SWainwright/BFriedman)
Mr. Roger Wentz, ATSSA Mr. Jim Baron, ATSSA
SafetyField
E84-401 Chron E84-401 Reader

DF(IA-11 Rectangular Rapid Flashing Beacon)

M:\MUTCD\INTERIM APPROVALS\IA-11 Rectangular Rapid Flashing Beacon\

IA-11 - RRFB Interim Approval Policy Memo.doc