

Jonathan Burton¹, Daniel Orfeo¹, Logan Griswold¹,
Steven Stanley², Michelle Redmond², Tian Xia¹, Dryver Huston¹

¹College of Engineering and Mathematical Sciences, University of Vermont. ²Vermont Agency of Transportation

Introduction

The Vermont Agency of Transportation (VTrans) must inspect approximately 9,600 small culverts annually. During inspection, a small remotely controlled vehicle drives through a culvert and streams video of the culvert interior back to the operator. However, of the two inspection vehicles currently available to VTrans, the “Crawler” is too costly for widespread deployment, and the Hydraulic Inspection Vehicle Explorer (“HIVE”) is unable to transmit video from deep within long culverts. In this project, a next-generation culvert inspection vehicle, the “HIVE 2.0”, is designed to meet VTrans requirements for efficient and effective low-cost culvert inspection.

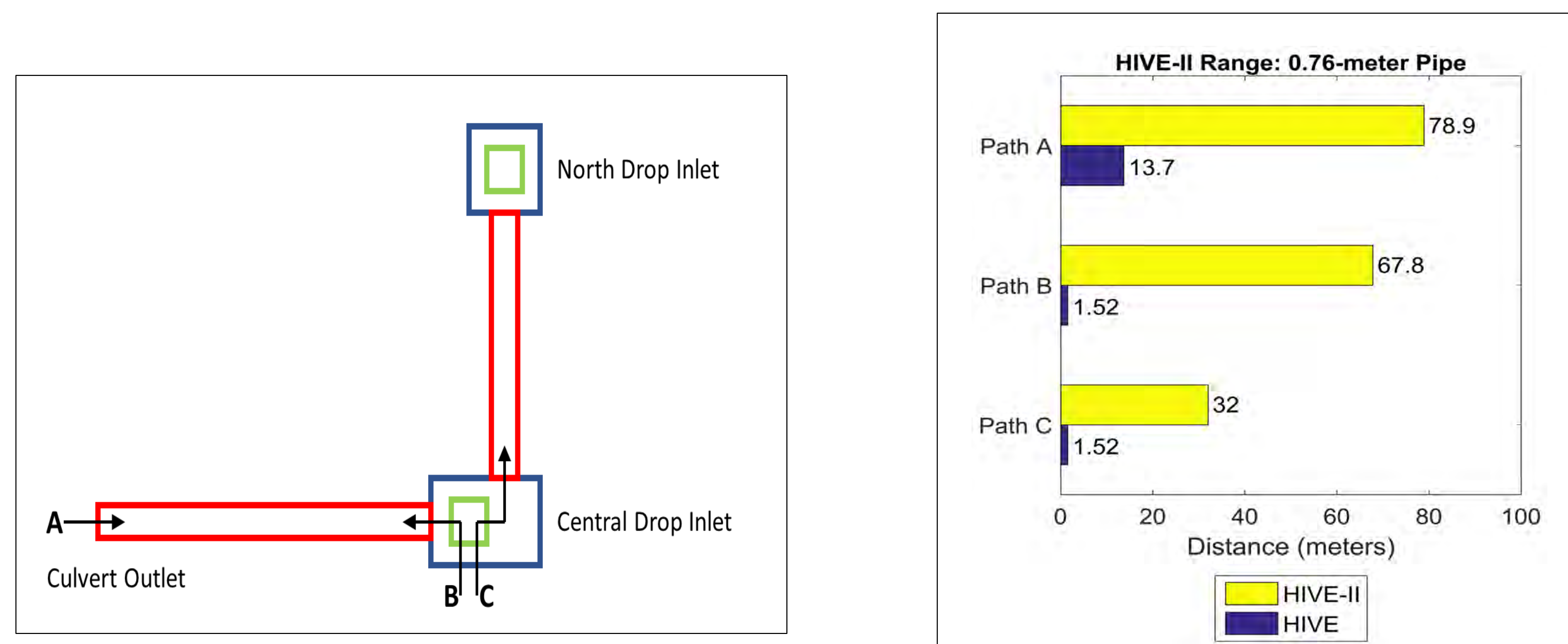

Figure 1. Left: Three inspection paths for VTrans Culverts 161158 and 161150 near U.S. Route 7 in Ferrisburgh, Vermont. Right: Performance of HIVE 2.0 versus original HIVE (Longer bars are better)

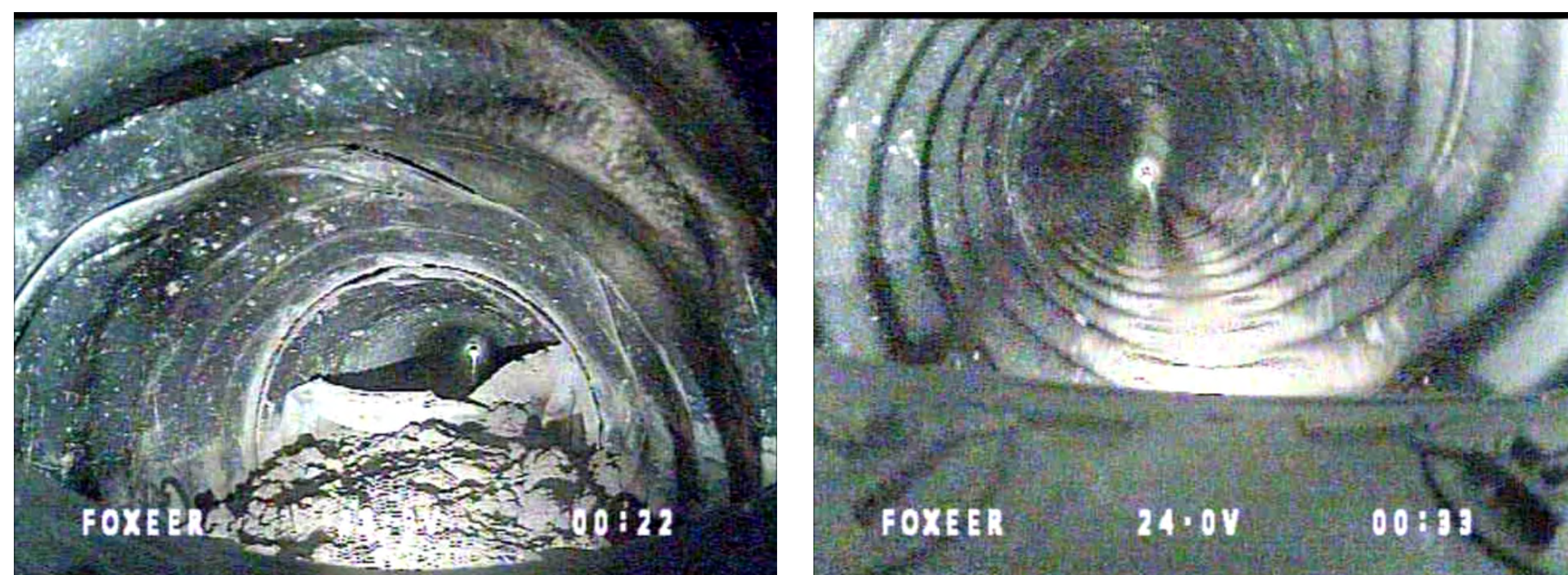

Figure 2. Photographs from the HIVE 2.0. Left: a partial blockage has caused sediment buildup in a culvert. Right: the culvert is clear after traversing the partial blockage.

Methodology

A Heng Long 1/16-scale remote control hobby tank is the chassis of the HIVE 2.0. Continuous tracks allow it to meet VTrans requirements to span a 6-inch (152 mm) separation gap and remain stationary on a 20-degree slope. Optimized equipment for radio control and video transmission provides extended telemetry range through small culverts. Total materials cost of the HIVE 2.0 is less than \$1200.

Conclusions

The original HIVE is quite capable but has limitations, Table 1. The HIVE 2.0 offers greater operating range, improved ability to traverse obstacles and gaps, and precise distance encoding from a tether. Figure 1 shows that the HIVE 2.0 equipped with a 5.8 GHz video transmitter provides at least 30.5 meters (100 feet) of additional operation and telemetry range in a difficult drop inlet inspection scenario.



Engineering Specifications	HIVE	HIVE 2.0
Live footage viewable at least 24.4 meters (80 feet) into 0.46-meter (18 inch) culvert	Does not meet specification	Meets specification
Live footage shall be viewable at least 24.4 meters (80 feet) into culvert with drop inlet	Does not meet specification	Meets specification
Vehicle shall span a gap of at least 0.152 meters (6 inches)	Does not meet specification	Meets specification
Vehicle shall remain still on a 20-degree slope	Does not meet specification	Meets specification
User shall know vehicle's distance in culvert to +/- 0.305 meters (1 foot) at all times	Moderately meets spec	Meets specification

Figure 3. Left: HIVE 2.0, Right: Performance of HIVE 2.0 versus original HIVE

Acknowledgments

This research was funded by the Vermont Agency of Transportation, project 19-03.

Reference

Burton J, Orfeo DJ, Griswold L, Stanley SK, Redmond M, Xia T, Huston D. (2021) “Culvert Inspection Vehicle with Improved Telemetry Range” Transportation Research Record, doi:10.1177/03611981211021850 published online July 27, 2021