

DETAIL A RESIDENTIAL DRIVE

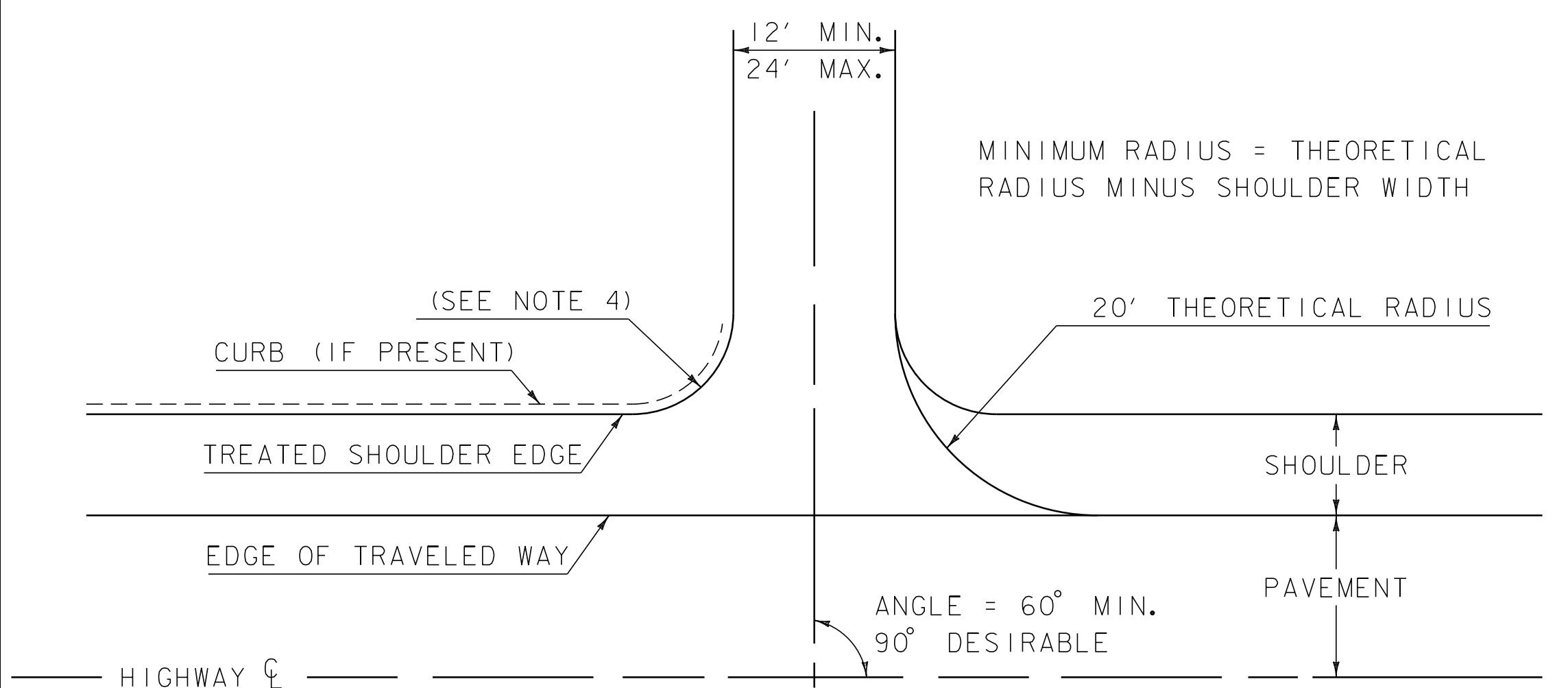

DETAIL B PROFILE OF DRIVE INTERSECTION (FILL SECTION)

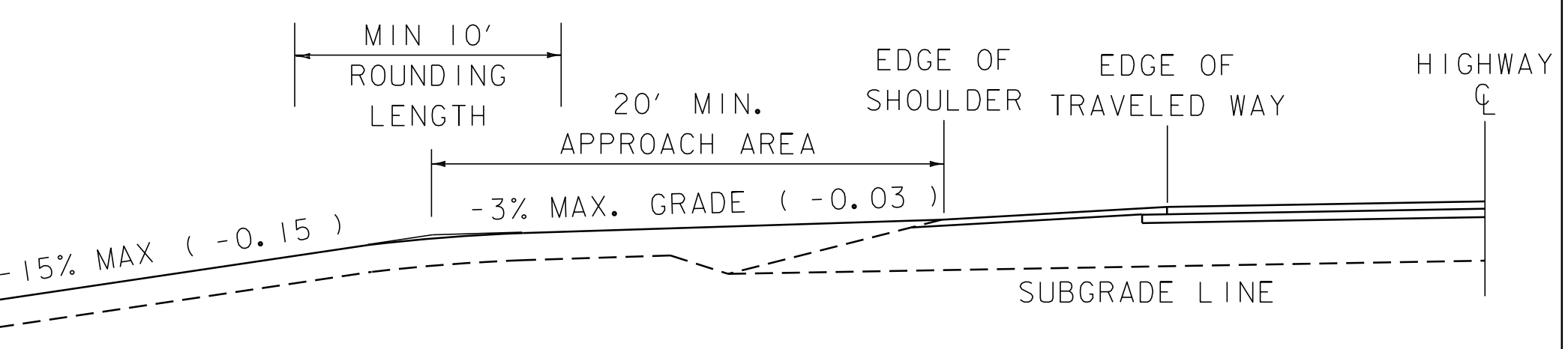

DETAIL C PROFILE OF DRIVE INTERSECTION SHOWING 5" DEPRESSION (CUT SECTION)

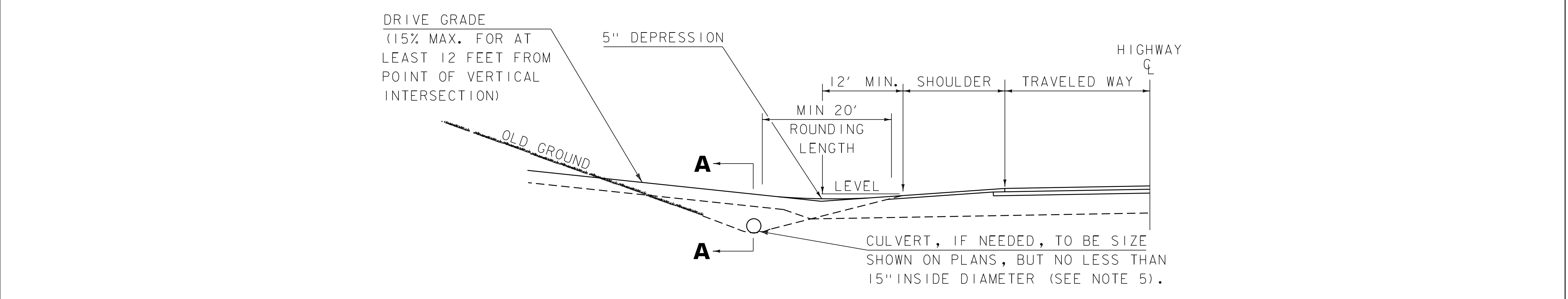

DETAIL D SECTION A-A DRIVE SIDE SLOPES TABLE

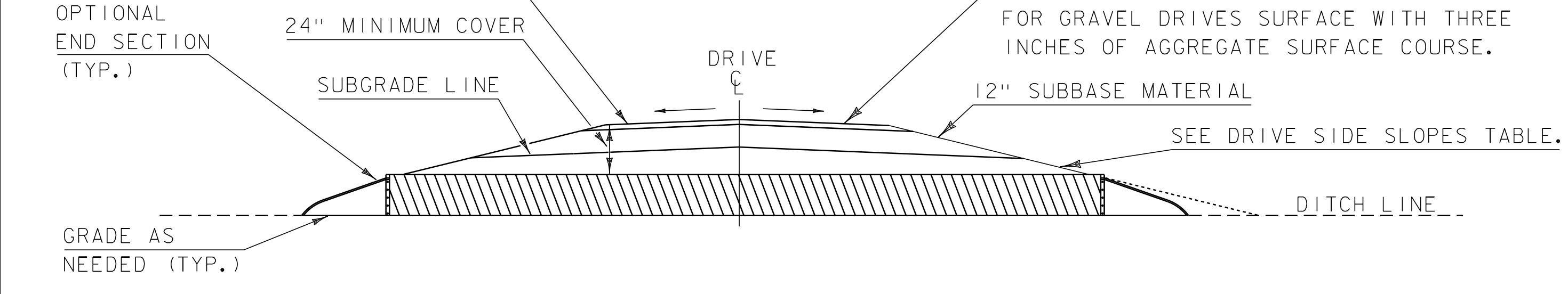

| LOCATION OF SLOPE | SLOPE RATE |
|---------------------------------------|--------------------------------|
| DESIGN SPEED > 40 MPH | 1:6 OR FLATTER |
| URBAN AREAS, OR DESIGN SPEED < 40 MPH | 1:4 DESIRABLE 1:2 ALLOWABLE |
| OUTSIDE CLEAR ZONE | 1:2 OR FLATTER |

- THIS SHEET IS INTENDED FOR USE BY DESIGNERS ON HIGHWAY PROJECTS AND IN CONJUNCTION WITH A PERMIT FOR WORK WITHIN HIGHWAY RIGHTS OF WAY. ALL CONSTRUCTION REQUIRED BY THE PERMIT AND INDICATED ON THIS SHEET SHALL BE THE RESPONSIBILITY OF THE APPLICANT AND IS SUBJECT TO THE APPROVAL OF THE VERMONT AGENCY OF TRANSPORTATION. WHEN USED WITH THE PLANS FOR A HIGHWAY CONSTRUCTION PROJECT, THIS SHEET IS INTENDED TO BE A GUIDE FOR THE DESIGNER CONCERNING DRIVE WIDTHS, HORIZONTAL, VERTICAL AND GEOMETRIC CHARACTERISTICS.
- DEPTH OF SUBBASE AND PAVEMENT TO BE THE SAME AS HIGHWAY OR AS SHOWN IN DETAIL D WITHIN THE LIMITS OF THE HIGHWAY RIGHT-OF-WAY.
- VEHICULAR ACCESS FROM PARKING AREAS TO THE RIGHT-OF-WAY AT OTHER THAN APPROVED ACCESS POINTS WILL BE PREVENTED BY THE CONSTRUCTION OF CURBING OR OTHER SUITABLE PHYSICAL BARRIER.
- IF CURB IS PRESENT, SEE APPROPRIATE CURB DETAIL STANDARD.
- CIRCULAR DRAINAGE CULVERTS UNDER DRIVES SHALL HAVE A MINIMUM INSIDE DIAMETER (I.D.) OF 15" OR AS OTHERWISE SHOWN ON THE PLANS. PIPE ARCHES USED UNDER DRIVES SHALL HAVE A MINIMUM INSIDE CROSS-SECTIONAL AREA EQUIVALENT TO THAT PROVIDED BY A 15" CIRCULAR PIPE. IF A CULVERT LARGER THAN 15" IS LOCATED UPSTREAM OF THE PROPOSED CULVERT THEN THE NEW CULVERT SHALL, AT A MINIMUM, MATCH THE SIZE OF THE UPSTREAM CULVERT.
- THE OFFSET BETWEEN THE PROPERTY LINE AND THE EDGE OF THE DRIVEWAY MAY BE GOVERNED BY LOCAL ZONING LAWS. DRIVEWAY WIDTH RESTRICTIONS SHOWN PERTAIN ONLY TO THE AREA WITHIN THE HIGHWAY R.O.W. OR THE END OF THE TURNING RADIUS WHICHEVER IS GREATEST.
- DRIVEWAY GRADES STEEPER THAN THOSE SHOWN MAY BE ALLOWED AS LONG AS A 20' APPROACH AREA IS ACHIEVED FOR THE VEHICLE TO PAUSE BEFORE ENTERING THE HIGHWAY.
- THIS STANDARD APPLIES TO FIELD DRIVES, LOGGING DRIVES, AND RESIDENTIAL ACCESSES SERVING UP TO TWO SINGLE FAMILY HOMES OR A DUPLEX. FOR LARGER RESIDENTIAL DEVELOPMENTS, SUBDIVISIONS AND OTHER COMMERCIAL ACCESSES SEE VTRANS STANDARD B-71B.
- INTERSECTION SIGHT DISTANCES, AND STOPPING SIGHT DISTANCE, EQUAL TO OR GREATER THAN THOSE SHOWN BELOW, SHOULD BE PROVIDED IN BOTH DIRECTIONS FOR ALL DRIVES ENTERING ON PUBLIC HIGHWAYS, UNLESS OTHERWISE APPROVED BY THE AGENCY OF TRANSPORTATION. INTERSECTION SIGHT DISTANCE IS MEASURED FROM A POINT ON THE DRIVE AT LEAST 15 FEET FROM THE EDGE OF TRAVELED WAY OF THE ADJACENT ROADWAY AND MEASURED FROM A HEIGHT OF EYE OF 3.5 FEET ON THE DRIVE TO A HEIGHT OF 3.5 FEET ON THE ROADWAY. STOPPING SIGHT DISTANCE IS MEASURED FROM AN EYE HEIGHT OF 3.5 FEET TO AN OBJECT HEIGHT OF 2.0 FEET ON THE ROADWAY.
- FOR DRIVEWAY AND INTERSECTION SPACING DISTANCES REFER TO THE "VERMONT AGENCY OF TRANSPORTATION ACCESS MANAGEMENT PROGRAM GUIDELINES" LATEST REVISION.

SIGHT DISTANCE TABLE

| POSTED SPEED OR DESIGN SPEED (MPH) | MINIMUM STOPPING SIGHT DISTANCE (FT) | MINIMUM INTERSECTION SIGHT DISTANCE (FT) |
|------------------------------------|--------------------------------------|--|
| 25 | 155 | 280 |
| 30 | 200 | 335 |
| 35 | 250 | 390 |
| 40 | 305 | 445 |
| 45 | 360 | 500 |
| 50 | 425 | 555 |
| 55 | 495 | 610 |

THE ABOVE VALUES ARE TAKEN FROM THE 2011 AASHTO "A POLICY ON GEOMETRIC DESIGN OF HIGHWAYS & STREETS."

| REV. | DATE | DESCRIPTION |
|---------------------------|--------------|-------------------|
| 0 | JUL. 1, 2019 | ORIGINAL APPROVAL |
| | | |
| | | |
| | | |
| OTHER STANDARDS REQUIRED: | | |

RESIDENTIAL DRIVES



STANDARD
B-71A